

TOP CLASS

Stand alone sinewave inverter

TC13/12, TC20/12

TC15/24, TC22/24, TC30/24

TC22/48, TC35/48

TC25/110, TC20/36

Instructions for installation and operation



A product of:

Advanced Solar Products AG

CH-8637 Laupen / ZH

Switzerland

www.asp-ag.com



Made in Switzerland

About this Manual

Congratulations on your purchase of a TOP CLASS sinewave inverter. You are the owner of the finest engineered and highest quality sinewave inverter. We have dedicated our product's, our services and ourselves to the satisfaction of every customer.



This manual for installation and operation contains important information about this unit. Please familiarise yourself with all the information contained in these instructions before installing and operating this unit. This will help you to get acquainted properly with this unit and make full use of its advanced technical features under all operating conditions.

Should you encounter problems while installing or running this unit, please contact the dealer

you purchased the unit from or a dealer authorised by ASP.

Improper assembly, installation and maintenance may impair the safety and function of this unit. For this reason make sure that you understand all the information in this manual before beginning the assembly and installation procedure.

ASP Advanced Solar Products AG, CH-8637 Laupen/ZH

Limitation of liability

Since neither the observance of these instructions for installation and operation, nor the conditions and methods of installation, operation, utilisation and maintenance of the unit can be supervised by ASP, we don't assume any responsibility or liability for loss, damage or costs arising from using this unit or in any way connected with faulty installation, improper operation or incorrect utilisation and maintenance.

Furthermore we don't assume any responsibility for infringement of patent rights or violations of the rights of third parties arising from the utilisation of this unit.

We reserve the right to make product changes, change technical specifications or these instructions without prior notice.

Important! Please be informed that units without CE-declaration can only be used on your own liability in european countries. If you have an unit without CE please contact your local dealer.

WARNING! Unauthorised repairs and operation of this device for any use other than that for which it was intended will result in loss of warranty. If you have problems with the unit ASP will provide you with the authorization necessary to return or repair a unit.

ASP Advanced Solar Products AG
Hauptstrasse 36B
CH-8637 Laupen/ZH
Switzerland

Phone. +41-(0)55-246 41 14
Fax: +41-(0)55-246 41 16
Internet: www.asp-ag.com
Email: aspinfo@bluewin.ch

Environmental protection



Recycling raw materials instead of waste disposal. This unit is built of valuable materials and is easy to recycle. The unit, accessories and packaging should be sorted for environment-friendly recycling. Please keep packaging for retransport the inverter later.

To prevent damage during transport we have to use and bill you a new packaging if we receive the unit not with original packaging. Thank you.

Precautions

Warning! In this unit potential differences of up to 1000V occur during operation and can result in death or serious bodily injury. Use extreme caution while operating and always observe precautions as:

The unit must be connected by a professional electrician only.

Only specially trained maintenance and service personnel are permitted to test and repair this unit.

This personnel further must be familiar with this manual and all domestic regulations.



No AC-generator or power supply is allowed to connect to this unit. Connecting mains power, AC-Generator or an other inverter to AC-output will damage the unit immediately. Excess voltage applied to the inputs and outputs may result in destruction of the unit. Charging the battery with a dynamo while the inverter is connected to the battery, may damage the inverter. Please ask your dealer if you have any questions. Take care of regulations for lightning protection.

The unit is tested by the manufacturer and it is not allowed to change anything! Without a written permission of ASP AG you will lose warranty if you repair the unit. Please refer to the warranty information.

Any work performed on this unit, its installation and electrical connection must be carried out in compliance with national electric codes and local regulations, which may deviate from those contained herein. Refer to responsible authorities for relevant information.

Operate the device only when all factory-supplied covers are available and in place. Temperatures at the heat sink of the device may be as high as 80 degrees C during operation. Obstruction of the ventilation of the unit may result in overheating and thus in failure of the unit.

Always keep the unit and the ventilation slots clean. Do not cover up or place any item on ventilation holes or cooling components.

Please note the permissible ambient conditions for operating the unit.

Automatic restart of the unit may occur after fault clearance.

Please note that also under standby operation, 230V test voltage pulses are present at the inverter AC-output. The inverter is still ready to run. To be sure that the unit is completely switched off you have to switch the main circuit breaker in OFF-position or disconnect the battery.

Warning! Inbuilt, large electrolytic capacitors will hold DC-voltage for extended periods.



Do not use any measuring equipment damaged or defective.

Contact with energized parts can result in serious or fatal injury. Please note that, even under excessively light load or in stand by operation, high voltage can be present at the AC-output.

Maintenance and Spare parts

This unit is maintenance-free.

Proper functioning of the unit and electrical connections must be inspected at regular intervals – we recommend once a year – by trained electrical specialists. The routine inspection should include the entire electrical system.

Should malfunctions of the unit occur despite these inspections, the unit must be returned to the manufacturer for repair. Original spare parts are only available from ASP. ASP will provide you with the authorization necessary to return a unit for repair. Before you call please prepare you for the following questions: Type of unit, DC-voltage, manufacturing date, date of purchase, kind of fault, connected loads.

1. Unpacking the unit

Please check if the unit has no visible damage. If the unit is damaged you must inform your dealer within 3 days after receiving the unit.

2. Function, technology

This inverter is designed to convert DC-battery voltage (direct voltage) to 230V AC (sinusoidal alternating voltage). Voltage controlled, the inverter provides a stabilised, crystal-accurate alternating voltage (different voltages and frequencies refer to the indication label). With a sinewave inverter almost any type of electric consumer may be connected as for example energy saving lights, fluorescent tubes, computers, Radio and HIFI-equipment and other household appliances, freezers, pumps, motors etc.

Due to a high degree built-in safety, excellent dynamic response, a surge-proof and overload-proof output, it is very simple to operate a broad range of applications.

The "heart" of the inverter is a very powerful RISC-microprocessor of the latest generation.

This microprocessor is responsible for the real time computing of the output sinewave shape, for the process control of the output voltage, for the supervision of the battery (dynamic) and the inverter temperature.

The power stage features modern Power Mosfet transistors. These transistors are the key to the high partial-load efficiency and superb overload capability. The power transistors are protected by independent intelligent protection circuits. The inverter is further more protected against DC-overvoltage (static) and short circuit on AC-output.

The battery input side is equipped with a thermal/magnetic circuit breaker for extreme overload protection of your system (TC 13/12, TC 20/12, TC 30/24 has no circuit breaker at the input).

The superb toroidal transformer has very low magnetic losses, high efficiency and a very low RFI-radiation level. The transformer design provides a high efficiency over a wide operating range. No electrical connection between DC-input and AC-output due to the transformer. It complies with the following guidelines: IEC 742, EN 60742, VDE 0551 TI, SEMLO 9742.

The whole control electronics are manufactured in SMD technology to ensure a high standard of quality and reliability.

Schematic

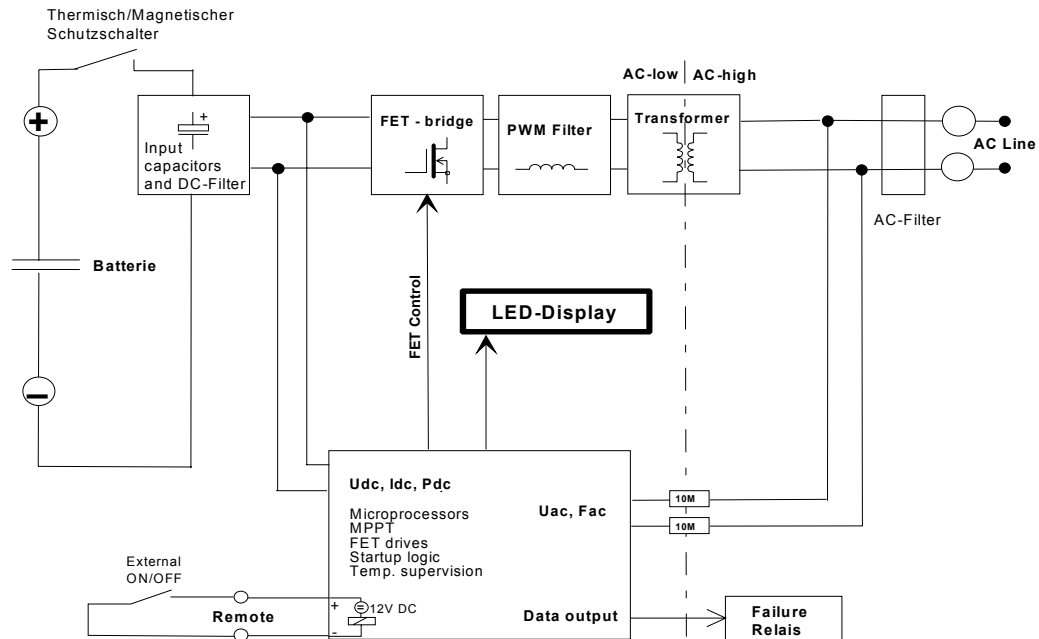

3. General information

Always check the power draw of your appliances. Electrical equipment as motors, pumps, compressors etc. need more power while starting up. Start up power draw can be much higher than P_{nom} . For this applications the inverter is able to supply up to 300% surge power for a short time.

Be careful if you use pumps. Power declaration on pumps is normally not the electrical input power of the pump! The inverter switches off automatically if surge power is too high. If ambient temperature is higher than 20 degrees C, P_{nom} and overload capability of the inverter will be reduced.

Due to reduced cooling capacity' P_{nom} of the inverter is reduced if operation altitude is above 900 m ASL. Reduction of P_{nom} is approx. 1,5% per every additional 100 m more altitude.

Example: If a 1000 VA inverter is installed as high as 2500 m ASL maximal P_{nom} will be at 780VA only! If you use more power, overheating and associated premature disconnection of the inverter must be anticipated.

If you use the inverter under above conditions we recommend to use a bigger inverter.

4. Installation

The selection of a safe location for installing the inverter depends on the followinn criteria:

- Check indication label for correct DC-Voltage and AC-Voltage.
- The inverter can be used in any position.
- Protection from unauthorized access in particular of children's.
- Dry, dust free surroundings (max. 95% humidity, not condensing).
- Short distance between battery and inverter. Use a grounded metal pipe to reduce RFI emission and to prevent surroundings of fire. The inverter should not be mounted in the same room as the batteries are (gas of the batteries during charging).
- Adequate ventilation. Keep min.10 cm distance to other objects (except mounting side)
- Battery capacity must be at least 400Ah (TC800) – 1000Ah (TC3500). Using a smaller battery may damage the unit.
- If other DC-units are installed at the same battery, contact your dealer for more information.
- Protection of inverter and battery from the effects of water.
- Temperature range 0–50 degrees C.

- Only specially trained maintenance and service personnel are permitted to test this unit. This personnel further must be familiar with this manual and all domestic regulations before installing this unit.

5. Connecting the inverter

The DC-circuit breaker must be turned to OFF-position. **Note:** Inbuilt, large capacitors will hold DC-Voltage for extended periods. They still can have DC-Voltage even when the switch is in off position and the DC-Cables are disconnected from the battery!

First make AC-Connections. Connect the wires to the output clamps (see additional sheet). An additional AC-Circuit breaker (size refer to datasheet) has to be installed. We recommend to install an earth leakage protector for protection of personnel. Please observe domestic regulations when making connections!

To connect the Battery to the inverter use a wire with minimum cross section of 50mm². An additional DC-breaker must be installed direct at the battery. Before connecting the cables to the battery make sure that the polarity is correct! Applying of wrong polarity can damage the inverter.

NOTE: Please exercise extreme care when connecting the unit to a battery. Otherwise the inverter or the battery could be damaged!

Take care of correct grounding of the inverter and your equipment which is connected to the inverter. We recommend to use an earth cable with minimum cross section of 25mm² to ground the inverter.

6. Information for operation



Protect your inverter from rain. The unit is not designed to be used outdoor.

The DC-input breaker should be in "ON"-position all the time. In case of an error it will switch off automatically. If the inverter is switched off by the small switch at the display unit, the inverter needs no power from the battery. The inverter is short circuit protected at the AC-Output.

DC input of the inverter is monitored for overvoltage and undervoltage. The upper limit is static. If DC-Voltage is too high the inverter will switch off. Automatic restart follows after DC-Voltage is in the normal range.

The lower limit is dynamic (cut off voltage is lower if a big load is in use). This allows an optimal use of the battery capacity and protects your battery during small load operation.

Important: If the inverter has switched off automatically it still needs very little power from the battery!

Important: Always before you switch on the circuit breaker you must switch off the load.

TOP CLASS 20/12, 30/24, 35/48 and 25/110 only: Both of this inverters are equipped with an alarm relays. This relays is switching before the inverter cuts off due to battery low voltage. With the potentiometer located at the main board you are able to adjust the level for battery low voltage switch off.

7. Status LED-display

LED LOBAT: Battery voltage low. The inverter switches off automatically if DC-Voltage is out of range for more than 5 seconds (LED is blinking). **Warning!** The inverter restarts automatically if DC-Voltage is in permitted range.

LED OVERTEMP: Overtemperature. Overheating as a result of insufficient cooling or extended overload. The inverter switches off automatically

after 5 seconds. **Warning!** The inverter restarts automatically if temperature is in permitted range.

LED AC-OUTPUT:

During normal operation this LED emits a green light. Inverter ON-Output = 230V AC/50Hz.

During standby this LED blinks green. **Hint:** This LED blinks orange before the inverter switches to standby if the load is too small. Use this information to adjust the standby level to your load. If AC-Output transcends tolerance (for ex. because of short circuit at the AC-Output) this LED emits a red light.

Warning! The inverter restarts automatically after 20 seconds.

STDBY-ADJUST:

With this potentiometer placed next to the LED's you can adjust standby level in a range from app. 4 – 40 W or you can switch the inverter to continual operation. Turn the potentiometer completely counter clockwise: The inverter is always ON – no sleep mode. Turning the potentiometer clockwise: The standby level (for sleep mode) will increase from app. 4 W to 40 W (see hint).

Important: Each time a fault occurs, the inverter restarts automatically after 20 seconds or if the para-meters (for example temperature) are back in normal conditions after a fault. Time before the unit starts again can be from a few seconds to a few hours! Always switch off the unit if you work at your system or electric consumer.

Additional information about standby/sleep mode

This specially designed standby circuit (energy saving circuit) recognizes automatically if power is needed at the AC-Output.

If no power is needed and after a delay of 10 seconds the unit switches into standby/sleep mode. In this operation mode power draw of the unit is less than 2W. Every 800ms the inverter checks the AC-Output by emulating a true sinewave voltage. If power draw exceeds the adjusted sensitivity level the inverter switches on immediately. If no more power is needed the inverter switches back to standby mode after a delay of 10 seconds.

If you use a small not compensated load it may occur that the inverter is switching on and off all the time. If this occurs you should compensate the load or switch an additional load to the AC-output. Note: A lot of electrical equipment needs power even if they are switched off. Especially units as portable radios TV- and video equipment, plug in power supplies etc. may have still such a high power draw that the inverter recognizes a load and is not able to switch into standby/sleep mode.

The sense level is adjustable on the potentiometer next to the LED's. You can adjust sensitivity level from app. 4W to 40 W. Sensitivity level may slightly change depending on DC-Voltage of the battery and temperature of the inverter (app. ± 2W).

Units with remote input

- If your inverter is equipped with remote ON/OFF control use the clamps 1 and 2 to connect an external switch to the unit. This ports are electrically separated from the unit. The max. length of the wire should not exceed 20 m. The minimum size of the wire is 0.25 mm². Do not connect to power supply!

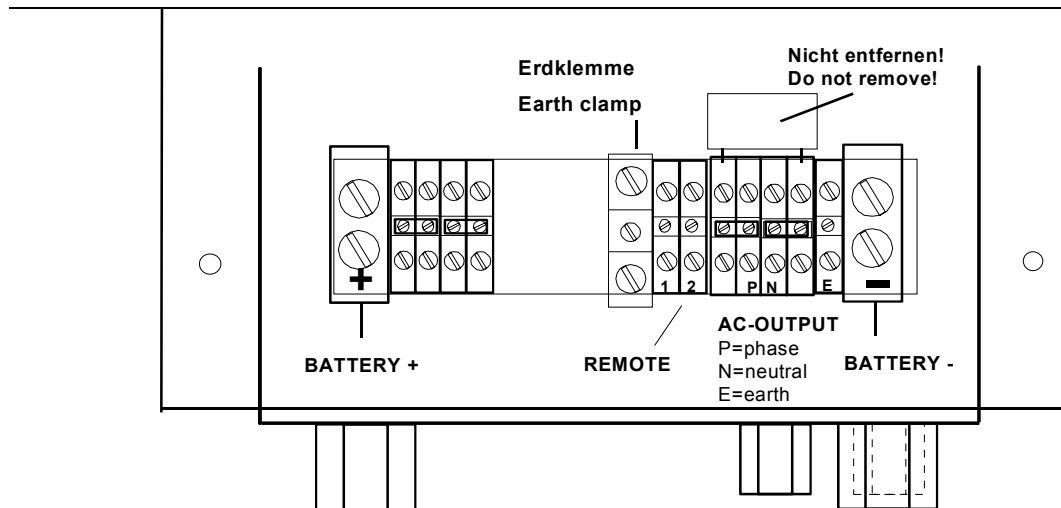

8. Fault clearance

AC-Output LED is flashing red and green

refer to point 7. LED-Display

The unit is noisy and switches off

The load is too big, battery is too small

It is not possible to set DC-Circuit breaker ON

wrong polarity at DC-input, wrong installation



DC-Circuit breaker switches to Off-Position

Overload operation for long time, reduce load



No function

Check wiring, check DC-Voltage

9. Technical data

TOP CLASS	TC13/12	TC20/12
		
Inverter		
Rated Voltage UDC_{IN}	12V	12V
Input Voltage Range	10.5 ... 16.0V DC	10.5 ... 16.0V DC
Dynamic Low Voltage Cut Off (depending on load)	10.5 ... 9.0V DC	10.5 ... 9.0V DC
Rated current IDC_{IN}	125A	195A
Current IDC_{IN} max.	340A	520A
Rated Power P_{10} (10 min at $T_A=20^\circ C$)	1400VA	2300VA
Rated Power P_{30} (30 min at $T_A=20^\circ C$)	1300VA	2000VA
Continuous Power P_D	1000VA	1800VA
Rated Output Voltage UAC_{OUT}	230V AC, $\pm 2\%$ (short circuit proof)	
Output Frequency	50Hz, $\pm 0.5\%$ (true sine wave)	
Rated Output Current IAC_{OUT}	5.7A	8.7A
Short Circuit Current IAC_K (max. 0.5s)	16A	24A
Allowable CosPhi	0.3 ... 1	
Efficiency Factor max.	92%	93%
Adjustable Standby Level (logarithmic)	5 ... 60W	
Consumption Standby/OFF	ca. 0.5W (Test impulse every 800ms) / 0W	
Consumption 230V AC OK	10W	16W
Reset after Short Circuit	every 60s	
Reset after Overload	every 60s	
Reset after Overtemperature	automatically after reaching semiconductor temp. $+45^\circ C$	
Reset after Battery failure	automatically after reaching UDC_{IN}	
General data		
Ambient Temperature range	$-25^\circ C$... $+50^\circ C$ (max. 95% rH, not condensing)	
DC- Breaker / fuse	no	no
Remote control ON / OFF	yes, with external switch	
Status indication	LED	LED
Alarm contact (insulated Relay contact)	no	yes
Toroidal Transformer (galvanically isolated)	IEC742, VDE0551	
Temperature and Load controlled fan	ON $55^\circ C$ / OFF $45^\circ C$, $P_D > 80\%$	
RS-232 Interface	no	no
Dimensions (L x W x H)	375 x 260 x 181 mm	456 x 320 x 211 mm
IP Protection	IP20	
Standards	CE	
Weight	15.5 kg	20 kg
Warranty	2 years	



Technical changes reserved (02/2003)

TOP CLASS	TC15/24	TC22/24
		
Inverter		
Rated Voltage UDC _{IN}	24V	24V
Input Voltage Range	21.0 ... 32.0V DC	21.0 ... 32.0V DC
Dynamic Low Voltage Cut Off (depending on load)	21.0 ... 18.0V DC	21.0 ... 18.0V DC
Rated current IDC _{IN}	72A	110A
Current IDC _{IN} max.	140A	205A
Rated Power P ₁₀ (10 min at T _A =20°C)	1700VA	2900VA
Rated Power P ₃₀ (30 min at T _A =20°C)	1500VA	2200VA
Continuous Power P _D	1200VA	2000VA
Rated Output Voltage UAC _{OUT}	230V AC, ± 2% (short circuit proof)	
Output Frequency	50Hz, ± 0.5% (true sinewave)	
Rated Output Current IAC _{OUT}	6.7A	9.6A
Short Circuit Current IAC _K (max. 0.5s)	16A	24A
Allowable CosPhi	0.3 ... 1	
Efficiency Factor max.	93%	93%
Adjustable Standby Level (logarithmic)	5 ... 60W	
Consumption Standby/OFF	ca. 0.5W (Test impulse every 800ms) / 0W	
Consumption 230V AC OK	12W	12W
Reset after Short Circuit	every 60s	
Reset after Overload	every 60s	
Reset after Overtemperature	automatically after reaching semiconductor temp. +45°C	
Reset after Battery failure	automatically after reaching UDC _{IN}	
General data		
Ambient Temperature range	-25°C ... +50°C (max. 95% rH, not condensing)	
DC- Breaker / fuse	100A	125A
Remote control ON / OFF	yes, with external switch	
Status indication	LED	LED
Alarm contact (insulated Relay contact)	no	no
Toroidal Transformer (galvanically isolated)	IEC742, VDE0551	
Temperature and Load controlled fan	ON 55°C / OFF 45°C, P _D >80%	
RS-232 Interface	no	no
Dimensions (L x W x H)	385 x 260 x 182 mm	456 x 320 x 211 mm
IP Protection	IP20	
Standards	CE	
Weight	16 kg	20 kg
Warranty	2 years	



Technical changes reserved (02/2003)

TOP CLASS	TC30/24
	
Inverter	
Rated Voltage UDC_{IN}	24V
Input Voltage Range	21.0 ... 32.0V DC
Dynamic Low Voltage Cut Off (depending on load)	21.0 ... 18.0V DC
Rated current IDC_{IN}	150A
Current IDC_{IN} max.	340A
Rated Power P_{10} (10 min at $T_A=20^{\circ}C$)	3200VA
Rated Power P_{30} (30 min at $T_A=20^{\circ}C$)	3000VA
Continuous Power P_D	2700VA
Rated Output Voltage UAC_{OUT}	230V AC, $\pm 2\%$ (short circuit proof)
Output Frequency	50Hz, $\pm 0.5\%$ (true sinewave)
Rated Output Current IAC_{OUT}	13A
Short Circuit Current IAC_K (max. 0.5s)	35A
Allowable CosPhi	0.3 ... 1
Efficiency Factor max.	94%
Adjustable Standby Level (logarithmic)	5 ... 60W
Consumption Standby/OFF	ca. 0.5W (Test impulse every 800ms) / 0W
Consumption 230V AC OK	22W
Reset after Short Circuit	every 60s
Reset after Overload	every 60s
Reset after Overtemperature	automatically after reaching semiconductor temp. $+45^{\circ}C$
Reset after Battery failure	automatically after reaching UDC_{IN}
General data	
Ambient Temperature range	$-25^{\circ}C$... $+50^{\circ}C$ (max. 95% rH, not condensing)
DC- Breaker / fuse	no
Remote control ON / OFF	yes, with external switch
Status indication	LED
Alarm contact (insulated Relay contact)	yes
Toroidal Transformer (galvanically isolated)	IEC742, VDE0551
Temperature and Load controlled fan	ON $55^{\circ}C$ / OFF $45^{\circ}C$, $P_D > 80\%$
RS-232 Interface	no
Dimensions (L x W x H)	456 x 320 x 211 mm
IP Protection	IP20
Standards	CE
Weight	31 kg
Warranty	2 years

Technical changes reserved (02/2003)

TOP CLASS	TC22/48	TC35/48
		
Inverter		
Rated Voltage UDC _{IN}	48V	48V
Input Voltage Range	42.0 ... 64.0V DC	42.0 ... 64.0V DC
Dynamic Low Voltage Cut Off (depending on load)	42.0 ... 36.0V DC	42.0 ... 36.0V DC
Rated current IDC _{IN}	54A	80A
Current IDC _{IN} max.	96A	210A
Rated Power P ₁₀ (10 min at T _A =20°C)	2700VA	3900VA
Rated Power P ₃₀ (30 min at T _A =20°C)	2200VA	3500VA
Continuous Power P _D	2000VA	3200VA
Rated Output Voltage UAC _{OUT}	230V AC, ± 2% (short circuit proof)	
Output Frequency	50Hz, ± 0.5% (true sinewave)	
Rated Output Current IAC _{OUT}	9.6A	15.6A
Short Circuit Current IAC _K (max. 0.5s)	16A	24A
Allowable CosPhi	0.3 ... 1	
Efficiency Factor max.	93%	93%
Adjustable Standby Level (logarithmic)	5 ... 60W	4 ... 40W
Consumption Standby/OFF	ca. 0.5W (Test impulse every 800ms) / 0W	
Consumption 230V AC OK	12W	12W
Reset after Short Circuit	every 60s	
Reset after Overload	every 60s	
Reset after Overtemperature	automatically after reaching semiconductor temp. +45°C	
Reset after Battery failure	automatically after reaching UDC _{IN}	
General data		
Ambient Temperature range	-25°C ... +50°C (max. 95% rH, not condensing)	
DC- Breaker / fuse	80A	100A
Remote control ON / OFF	yes, with external switch	
Status indication	LED	LED
Alarm contact (insulated Relay contact)	no	yes
Toroidal Transformer (galvanically isolated)	IEC742, VDE0551	
Temperature and Load controlled fan	ON 55°C / OFF 45°C, P _D >80%	
RS-232 Interface	no	no
Dimensions (L x W x H)	456 x 320 x 211 mm	
IP Protection	IP20	
Standards	CE	
Weight	20 kg	30 kg
Warranty	2 years	

Technical changes reserved (02/2003)

TOP CLASS	TC25/110	TC20/36
		
Inverter		
Rated Voltage UDC_{IN}	110V	36V
Input Voltage Range	96.0 ... 148.0V DC	31.0 ... 47.0V DC
Dynamic Low Voltage Cut Off (depending on load)	96.0 ... 84.0V DC	31.0 ... 27.0V DC
Rated current IDC_{IN}	27A	61A
Current IDC_{IN} max.	74A	180A
Rated Power P_{10} (10 min at $T_A=20^\circ C$)	2900VA	2500VA
Rated Power P_{30} (30 min at $T_A=20^\circ C$)	2500VA	2200VA
Continuous Power P_D	2200VA	1800VA
Rated Output Voltage UAC_{OUT}	230V AC, $\pm 2\%$ (short circuit proof)	
Output Frequency	50Hz, $\pm 0.5\%$ (true sinewave)	
Rated Output Current IAC_{OUT}	12A	9A
Short Circuit Current IAC_K (max. 0.5s)	16A	24A
Allowable CosPhi	0.3 ... 1	
Efficiency Factor max.	93%	93%
Adjustable Standby Level (logarithmic)	4 ... 40W	
Consumption Standby/OFF	ca. 0.5W (Test impulse every 800ms) / 0W	
Consumption 230V AC OK	13W	12W
Reset after Short Circuit	every 60s	
Reset after Overload	every 60s	
Reset after Overtemperature	automatically after reaching semiconductor temp. +45°C	
Reset after Battery failure	automatically after reaching UDC_{IN}	
General data		
Ambient Temperature range	-25°C ... +50°C (max. 95% rH, not condensing)	
DC- Breaker / fuse	80A	63A
Remote control ON / OFF	yes, with external switch	
Status indication	LED	LED
Alarm contact (insulated Relay contact)	yes	no
Toroidal Transformer (galvanically isolated)	IEC742, VDE0551	
Temperature and Load controlled fan	ON 55°C / OFF 45°C, $P_D > 80\%$	
RS-232 Interface	no	no
Dimensions (L x W x H)	456 x 320 x 211 mm	456 x 320 x 211 mm
IP Protection	IP20	
Standards	CE	
Weight	25 kg	19.5 kg
Warranty	2 years	

Technical changes reserved (02/2003)

11. Additional sheet for cable connections

View of clamp on C-rail

Direct voltage (DC)

+ = battery plus (+)

- = battery minus (-)

Remote

1 = remote off-control

2 = remote off-control

Alternating voltage (AC)

P = phase

N = neutral

E = earth

TC20/12

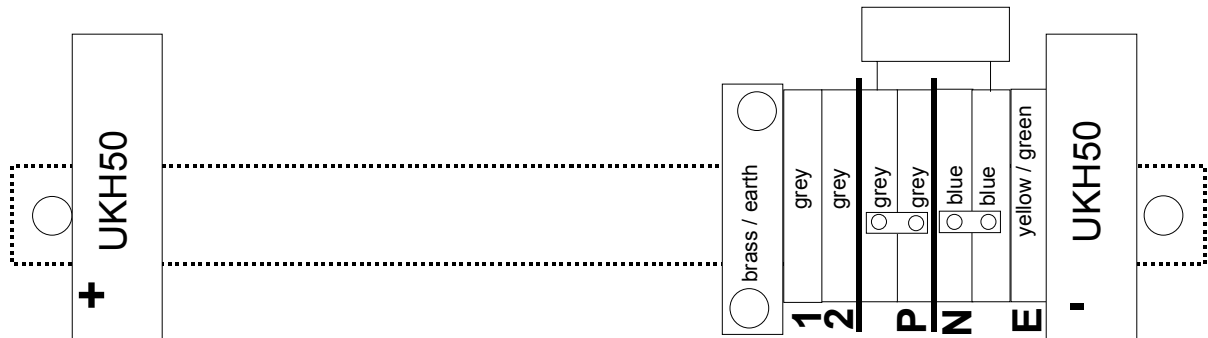

TC13/12

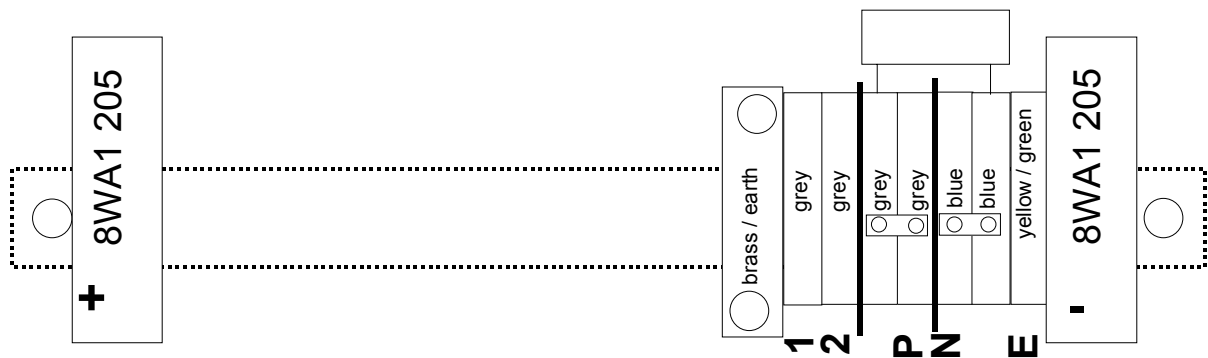

TC15/24

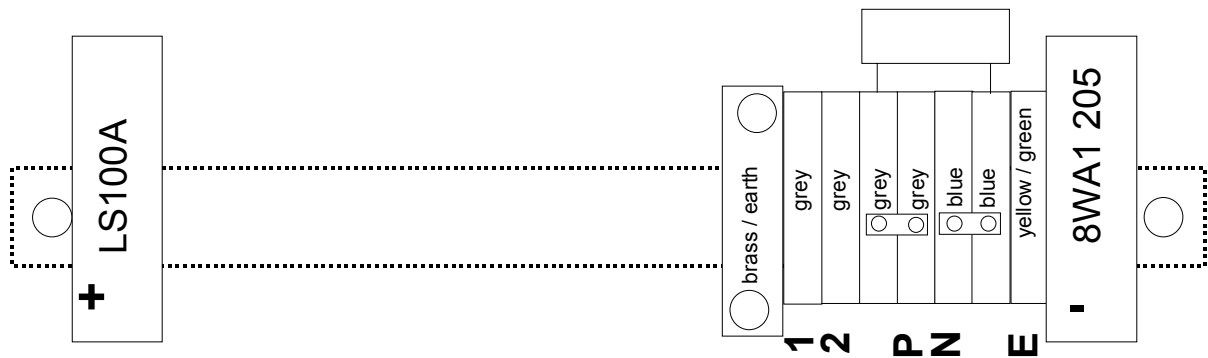

TC22/24

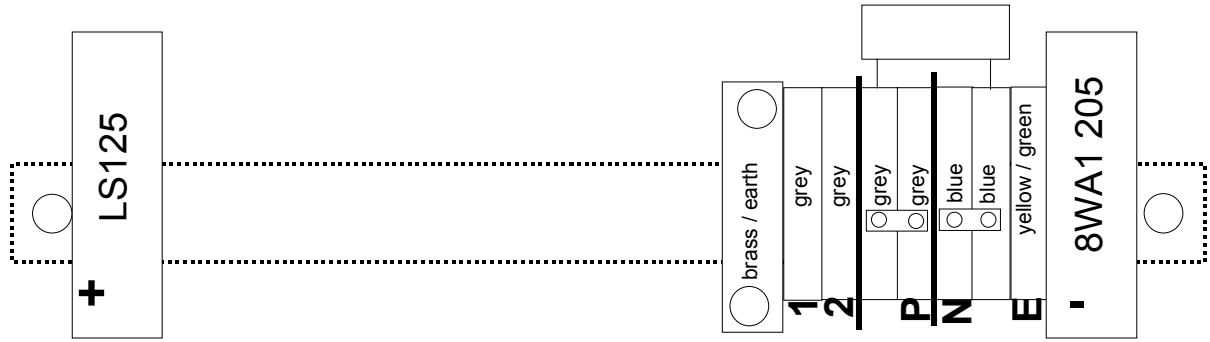

TC30/24

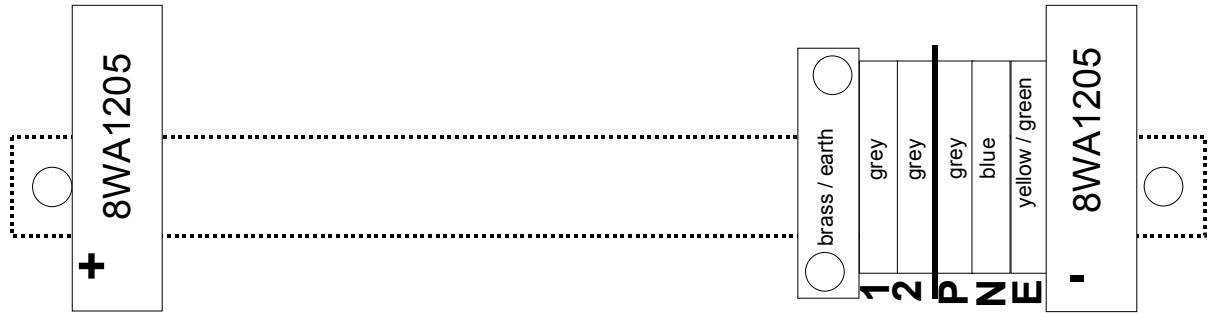

TC22/48

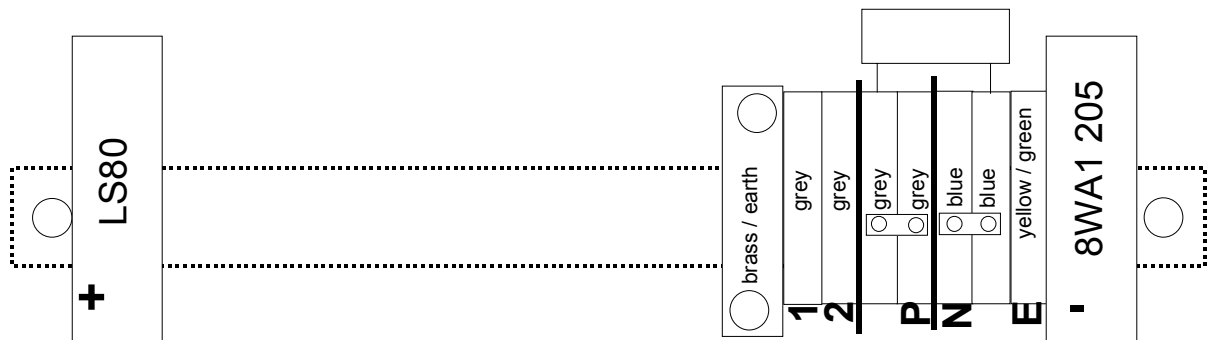

TC35/48

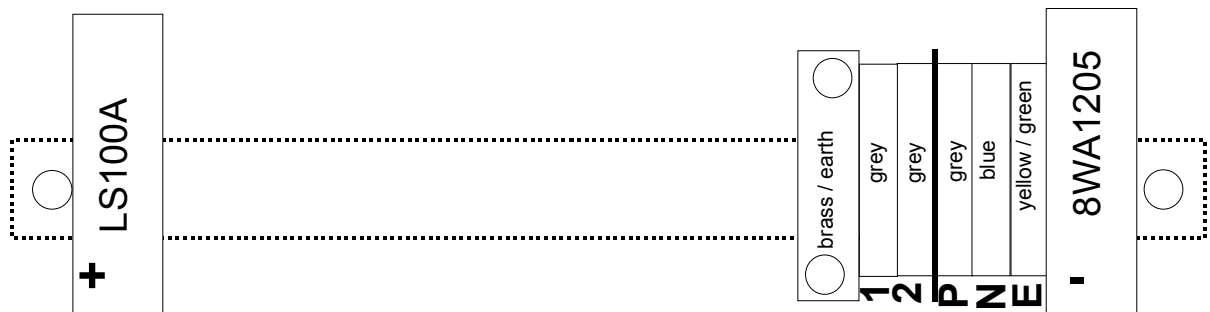

TC25/110

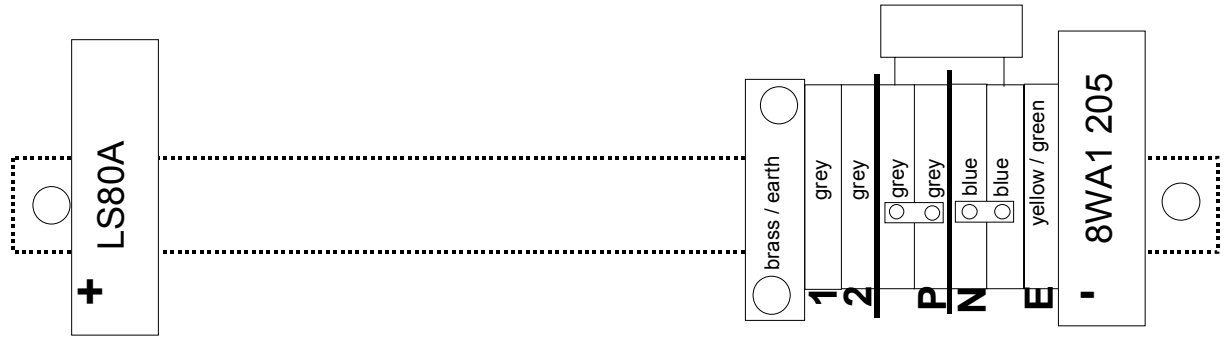

TC20/36

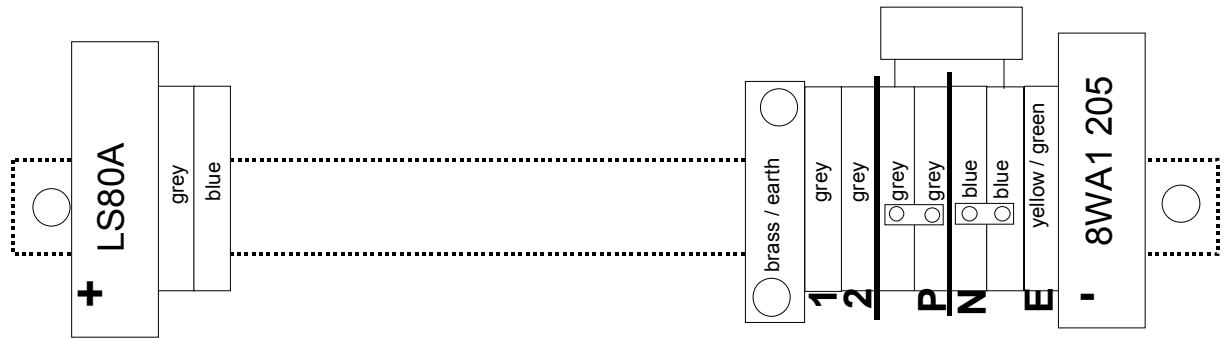

9. Warranty (short form)

Dear Customer,

Thank you for buying this ASP product. In the event that your ASP product needs guarantee service you should return it to the retailer from whom it was purchased.

We guarantee TOP CLASS appliances in accordance with statutory/country-specific regulations (proof of purchase by invoice or delivery note). Damage attributable to normal wear and tear, overload or improper handling will be excluded from the guarantee. In case of complaint please send the unit with the original packaging, undismantled to your dealer or an ASP service centre for inverters. Please be aware of the information we need to repair the unit as soon as possible (page 4, Maintenance and Spare parts).

ASP AG is not responsible for costs arising for transport of the unit or damage that occur if the unit is out of service. If you wish we will send you our complete documentation about our guarantee terms.

Frequently asking questions

CONTENT

- *What is a true sine-wave inverter?*
- *How to choose the right battery?*
- *What about battery fuses?*
- *How to choose the battery cables?*
- *What's cos phi?*
- *Why does my 600VA inverter not work on a load declared 600W?*
- *How to parallel inverters?*
- *Is there a need for series diodes on a solar field?*
- *Why does a grid connected inverter need earth connection with heavy (25mm²) cable?*
- *How to get inverters with different frequencies and/or different voltages?*
- *Why does the automatic load sense circuitry not sense some loads?*
- *How does the inverter handle overload?*
- *What measures are taken to maintain the high quality of TOP CLASS inverters?*

What is a true sinewave inverter?

An inverter is able to convert battery voltage (DC) to alternating current (AC) e.g. 110V AC/60Hz. This may be achieved in several ways. We would like to point out a few details.

Square wave inverters

The output of these inverters is a square voltage of 110V AC/60 Hz. The regulation of the output voltage is often very inaccurate and directly depending on the input voltage and on the output load.

Squarewave inverters may have very high efficiency for purely resistive loads ($\cos \phi = 1$, e.g. heaters). Switch mode power supplies (as load) may also give good results if the EMI regulations are met by the inverter.

Loads causing problems with squarewave inverters:

- Any loads with $\cos \phi$ other than 1 (inductive or capacitive loads).
- Energy saving lamps and other loads with capacitive voltage dividers. Current peaks caused by very steep voltage slopes cause massive reduction of life time.
- Interference (white stripes etc.) and audio noise in hi fi, video or TV units.
- Loads with phase control, sensitive electronics.
- Electric motors, there are two major problems: Motors running very hot due to current peaks caused by square wave, motor bearings wear out quickly due to torque variations.

PWM Inverters, modified square wave inverters, adapted sine wave inverters etc.

All of these inverters have in common the sharp voltage slopes of the squarewave inverters. The word "sine" is only introduced by marketing people. The only advantage of these inverters is the regulation of the output voltage independently of input voltage and load.

Pure sinewave inverters

This technology is state of the art for several years now. There is no reason for any other inverter technology except price.

The pure sinewave is a "natural" waveform as created by any power station available at your home wall socket.

Any mains load available was created for use with sinewave electricity!

Sinewave inverters are more complicated to build thus resulting in increased manufacturing costs. The sinewave shape is synthesized by an additional PWM filter at the output of the inverter. Idle consumption is slightly higher than squarewave inverters. The biggest advantage is found in the high efficiency and hassle free operation of almost any load.

More technical details (overview):

- 50/60Hz technology: Isolation and voltage step between DC and AC side is achieved by iron transformers. Very high safety standard. Increased lifetime due to reduction of semiconductors. Battery acts as storage for reactive currents. The only disadvantage is high weight of iron transformers.
- High frequency technology: These units utilise a HF transformer for isolation/ voltage step. Reduction of weight but increased number of electronic parts. Efficiency is similar to 50/60 Hz technology with resistive loads but there is no chance to use the battery as storage for inductive currents. Loads with low cos phi can cause problems.
- High frequency inverters without isolation between DC / AC: Only used in cheap product's. Not recommended for safety reasons, no up to date technology.

How to choose the right battery?

Inverters should be operated on batteries of appropriate size. The battery should be cycle proof. Generally for lead acid batteries: the shorter the discharge time, the lower the energy usable. E.g.: If a battery can deliver 10 Amps for 10 hours, it will deliver 100 Amps only for 20 to 30 minutes. You should choose the battery size for an operation time of several hours with your estimated load. Additionally you should only allow for a discharge down to 60 to 70% of full capacity in order to increase battery lifetime.

E.g.: Lifetime of a battery may be 5000 discharge cycle with 20% discharge per cycle. The same battery will only live for approx. 2000 discharge cycles if every cycle is 40% discharge.

What about battery fuses?

Fuses should be placed as close as possible to the batteries in order to protect the whole battery cable. In case of cable short fire might occur!

How to choose the battery cables?

DC current in battery cables causes voltage drop according to Ohms law $V=R*I$. As general guidance: 1m of cable 25mm² has approx. resistance of 0.001 Ohm. This value multiplied by battery current results in voltage drop. Example: TC 1312 with nominal load, DC current approx. 140Amps, 1.5m distance from batteries, $V=2*1.5*140*0.001=0.42$ Volts, heat dissipation in Cables 60 Watts approx! This application should have 35mm² or even 50mm². Place the inverter as closely to the battery as possible. Use inverters with higher input voltage if possible.

Remark regarding Piccolo12V:

Piccolo12V is delivered with car cigarette lighter plug. Even though we use the best plugs available, high losses are monitored in these plugs when operated at full load. For high output power we recommend to connect Piccolo12V directly to the battery.

What's cos phi?

With heavy inductive loads the product $V*I$ (VA on AC side) is much larger than the actual watts delivered. E.g. : Inductive motors, fluorescent lamps, etc. . This means some of the energy is stored in the inductivity of the load and then flows back to the battery. These inductive currents cause heat dissipation in the power semiconductors and in the cables as well. As the capacity is used up for reactive currents, there is "no room" for active currents.

Why does my 600VA inverter not work on a load declared 600W?

- With inductive loads the VA value is bigger than the Watts value. E.g. 600W load, cos phi 0.6 results in 1000VA!
- With motors often the mechanical output power is declared so the VA rating is even higher.
- Another cause for malfunction is inrush currents (5 to 10 times nominal current with motors).

How to parallel inverters?

- Stand alone inverters: paralleling is only possible on the DC side, AC sides always have to be isolated. Never connect your mains to the inverter output, immediate destruction will result.

Why does an inverter need earth connection with heavy (25mm²) cable?

The main function of the earth connection cable is lightning protection and interference suppression. The solar panel field acts as antenna which may transmit interference caused by switching slopes in the inverter. The inbuilt filter circuitry is only active with appropriate earth connection.

How to get inverters with different frequencies and/or different voltages?

Most of the TOP CLASS inverters are available for various frequencies/voltages. Different input voltage range is also possible. Ask your distributor for availability if you need any special inverter.

Why does the automatic load sense circuitry not sense some loads?

There are some limits to the load sensing circuitry. Since the internal measuring circuits are used for several different purposes, the sensing of very small loads can cause a problem for the inverter. Drifts of the sense circuitry over temperature and voltage may also cause drift. Some of the energy saving lamps have a very bad cos phi.

Some loads are detected correctly but turn off after 10 seconds because operating current is lower than inrush current.

Often the problem is solved by using a different brand of lamps.

We will improve load sensing with the next generation of inverters.

How does the inverter handle overload?

One of the most important features of an inverter is its capability to handle overload. It is absolutely necessary for start-up of motors, compressors and tools. In order to utilise the full overload potential of an inverter, follow these guidelines:

- appropriately sized battery bank
- well sized battery cables for minimising of voltage drop.
- Ambient temperature: The higher the ambient temperature, the lower the max. overload. The inverter monitors the output power and turns itself off in case of overload. Generally the inverter size should be chosen big enough to avoid self cut-off in normal operation.

Approx. cut-off time for resistive overload:

300%	10sec. approx.
200%	1 minute approx.
150%	2 minutes approx.
110%	20 minutes approx.

What measures are taken to maintain the high quality of TOP CLASS inverters?

Sinewave inverters are complex units both in design and manufacturing demanding a high degree of attention for all people involved.

Our inverters are manufactured according to ISO9001 consequently. This vouches for a high standard of quality. If for example a defective batch of components is discovered after shipment, tracing of the units is possible by serial number. Since each test procedure has to be met by the test crew, we can guarantee a high standard of quality for each unit shipped.