

TOP CLASS “COMBI”

Stand alone sinewave inverter with integrated battery-charger

TCNL13/12 and TCNL22/24

Instructions for installation and operation



A product of:

Advanced Solar Products AG
CH-8637 Laupen / ZH
Switzerland

www.asp-ag.com



Made in Switzerland

About this Manual

Congratulations on your purchase of a TOP CLASS sinewave inverter. You've become the owner of the finest engineered, highest quality sinewave inverter. We have dedicated our product's, our services and ourselves to the satisfaction of every customer.



This manual for installation and operation contains important information's about this unit. Please familiarise yourself with all the information's contained in these instructions before installing and operating this unit. This will help you to acquaint yourself properly with this unit and make full use of its advanced technical features under all operating conditions.

Should you encounter problems while installing or running this unit, please contact the dealer you purchased the unit from or a dealer authorised by ASP.

Improper assembly, installation and maintenance may impair the safety and function of this unit. For this reason make sure that you understand all the information's in this manual before beginning the assembly and installation procedure.

Thank you again for choosing to become a part of the ASP family!.

ASP Advanced Solar Products AG, CH-8637 Laupen/ZH

Limitation of liability

Since neither the observance of these instructions for installation and operation, nor the conditions and methods of installation, operation, utilisation and maintenance of the unit can be supervised by ASP, we don't assume any responsibility or liability for loss, damage or costs arising from using this unit or in any way connected with faulty installation, improper operation or incorrect utilisation and maintenance.

Furthermore we don't assume any responsibility for infringement of patent rights or violations of the rights of third parties arising from the utilisation of this unit.

We reserve the right to make product changes, change technical specifications or these instructions without prior notice.

Important: Please be informed that units without CE-declaration can only be used on your own liability in Europe countries. If you have an unit without CE please contact your local dealer.

WARNING! Unauthorised repairs and operation of this device for any use other than that for which it was intended will result in loss of warranty. If you have problems with the unit ASP will provide you with the authorisation necessary to return or repair a unit.

ASP Advanced Solar Products AG
Hauptstrasse 36B
CH-8637 Laupen/ZH
Schweiz

Tel. +41-(0)55-246 41 14
Fax: +41-(0)55-246 41 16
Internet: www.asp-ag.com
Email: aspinfo@bluewin.ch

Environmental protection



Recycling raw materials instead of waste disposal. This unit is built from valuable materials and is easy to recycle. The unit, accessories and packaging should be sorted for environment-friendly recycling. Please keep packaging for retransport the inverter later. To prevent damage during transport we have to use and bill you a new packaging if we receive the unit not with original packaging. Thank you.

Precautions

Warning! In this unit potential differences of up to 1000V occur during operation and can result in death or serious bodily injury. Use extreme caution while operating and always observe precautions as:

The unit must be connected by a professional electrician only.

Only specially trained maintenance and service personnel are permitted to test and repair this unit. This personnel further must be familiar with this manual and all domestic regulations.



Connecting mains power, AC-Generator or an other inverter to *AC-output* will damage the unit immediately. Excess voltage applied to the inputs and outputs may result in destruction of the unit.

Charging the battery with a dynamo while the inverter is connected to the battery, the inverter may be damaged. Please ask your dealer if you have any questions.

Take care of regulations for lightning protection.

The unit is tested by the manufacturer and it is not allowed to change anything! Without a written permission of ASP AG you will loose warranty if you repair the unit. Please refer to the warranty information's.

Any work performed on this unit, its installation and electrical connection must be carried out in compliance with national electric codes and local regulations, which may deviate from those contained herein. Refer to responsible authorities for relevant information's.

Operate the device only when all factory-supplied covers are available and in place.

Temperatures at the heatsink of the device may be as high as 80 degrees C during operation. Obstruction of the ventilation of the unit may result in overheating and thus in failure of the unit. Always keep the unit and the ventilation slots clean. Do not cover up or place any item on ventilation holes or cooling components.

Please note the permissible ambient conditions for operating the unit.

Automatic restart of the unit may occur after fault clearance.

Please note that also under standby operation, 230V test voltage pulses are present at the inverter AC-output. The inverter is still ready to run. To be sure that the unit is completely switched off you have to switch the main circuit breaker in OFF-position or disconnect the battery.

Warning! Inbuilt, large electrolytic capacitors will hold DC-voltage for extended periods.



Do not use any measuring equipment damaged or defective.

Contact with energised parts can result in serious or fatal injury. Please note that, even under excessively light load or in stand by operation, high voltage can be present at the AC-output.

Maintenance and Spare parts

This unit is maintenance-free.

Proper functioning of the unit and electrical connections must be inspected at regular intervals - we recommend once a year - by trained electrical specialists. The routine inspection should include the entire electrical system.

Should malfunctions of the unit occur despite these inspections, the unit must be returned to the manufacturer for repair. Original spare parts are only available from ASP. ASP will

provide you with the authorisation necessary to return a unit for repair. Before you call please prepare you for the following questions: Type of unit, DC-voltage, manufacturing date, date of purchase, kind of fault, connected loads.

Features

- True sine wave output for every load
- Automatic transfer switch, synchronisation and battery charge
- Power factor correction - for best possible performance
- High output charger - Charge up to 100% nominal power
- Multi stage charger with selectable charge cycle algorithm
- Suitable for sealed or lead acid batteries
- Overload capability up to 300%
- Remote battery temperature sensor
- RS232 interface for operation information
- Remote display panel optional

Function and Technology

The technology of the inverter is designed with the same reliable full bridge electronic technology well-established with all other ASP inverters. The incorporated design for high surge output eliminates start up problems when using heavy motors and compressors. Due to the latest know-how in drive technology switching losses are reduced and efficiency improved. To measure all relevant operating parameters the unit is equipped with very fast and accurate AD-converters. A state-of-the-art protection concept ensures perfect performance under all operating conditions. For the protection of the batteries an algorithm of analysing the load defines the adjustable cut off voltage.

Function of the charger

The charging rate equals the inverters nominal output; e.g. the charge rate of the TCNL22/24 2200VA 24V is 2200W maximum. A micro processor monitors the code of the batteries; e.g. I_{oU} for GEL-batteries or I_{UoU} for lead acid batteries.

Batteries are charged with optimum and careful performance and overcharging is impossible.

Code I_{oU}

This code is best to be used for GEL-batteries. Continued charging occurs up to the level set. The level is kept constantly while the current is reduced.

Code I_{UoU}

This code is best if short charging period is required. The code allows the batteries to stay connected with the charger without danger of overcharging.

The ASP inverter/charger units are micro processor controlled with a Power Factor Correction (COS $\phi=1$) responsible that the input wave of the generator is always of sine wave quality.

Automatically charging of the batteries occurs even if the battery voltage is below the nominal battery voltage range.

A static by-pass switch automatically connects mains power to the load in case of inverter failure or lo-battery.

An external temperature sensor for battery temperature compensation is delivered with the unit at no extra costs.

The following parameters are adjustable:

Charging code, maximum charge current, float voltage, boost level, boost time and generator running time.

Description of the by-pass switch

An integrated high current transfer switch (40A/230V) has the following functions:

- While appliances connected to mains power or generator via the by-pass switch the inverter synchronises with the AC source and charges the batteries;
- In case of mains failure or generator stop the load will be connected to the inverter output within less than 10ms to provide continuous AC power to the appliance in use.
- When mains or generator is re-connected, the inverter verifies the relevant parameter for 10-15 seconds before a smooth and imperceptible transfer takes place and charging starts.
- In case of empty batteries or inverter failure the load will always automatically switch to grid/generator.

Function of the RS232 interface

A standard RS 232 interface is integrated in the TCNL unit. All relevant operating data and adjustable parameters are available by connecting a computer to the standard 9pin connector.

The interface is equipped with the following features:

The interface is completely isolated from the unit;

- Power for the interface is delivered by an integrated but isolated source; no external power supply is needed!
- Any standard terminal software is suitable with a baud rate of 4800bps.
- Data is accessible within a reach of up to 30m or up to 60m with the optional remote display panel.

Function of the optional remote control panel

An optional external LC-Display is available for easy operation and controlling of the unit. With the optional control panel all relevant data is available as true text message to monitor and control the unit. The LC-display with back light features 16 digits and provides all operational data, the settings and true text error messages.

Unit ON= Operational data (battery voltage, battery charge or discharge current, AC power, AC voltage, inverter mode, inverter temperature, graph for actual power, errors: overload, overheat, AC low, DC low/high, service messages)

Unit OFF= actual settings (max. charge/current, battery type/algorithm, under voltage cut off level, float level, boot time, generator running time, load sense level)

An additional RS232 interface is included in the remote control panel. Jog Dial menu operation provides "Plug and Play" information.

With the toggle switch it is possible to initialize boost mode or manual generator start/stop

Block-diagram

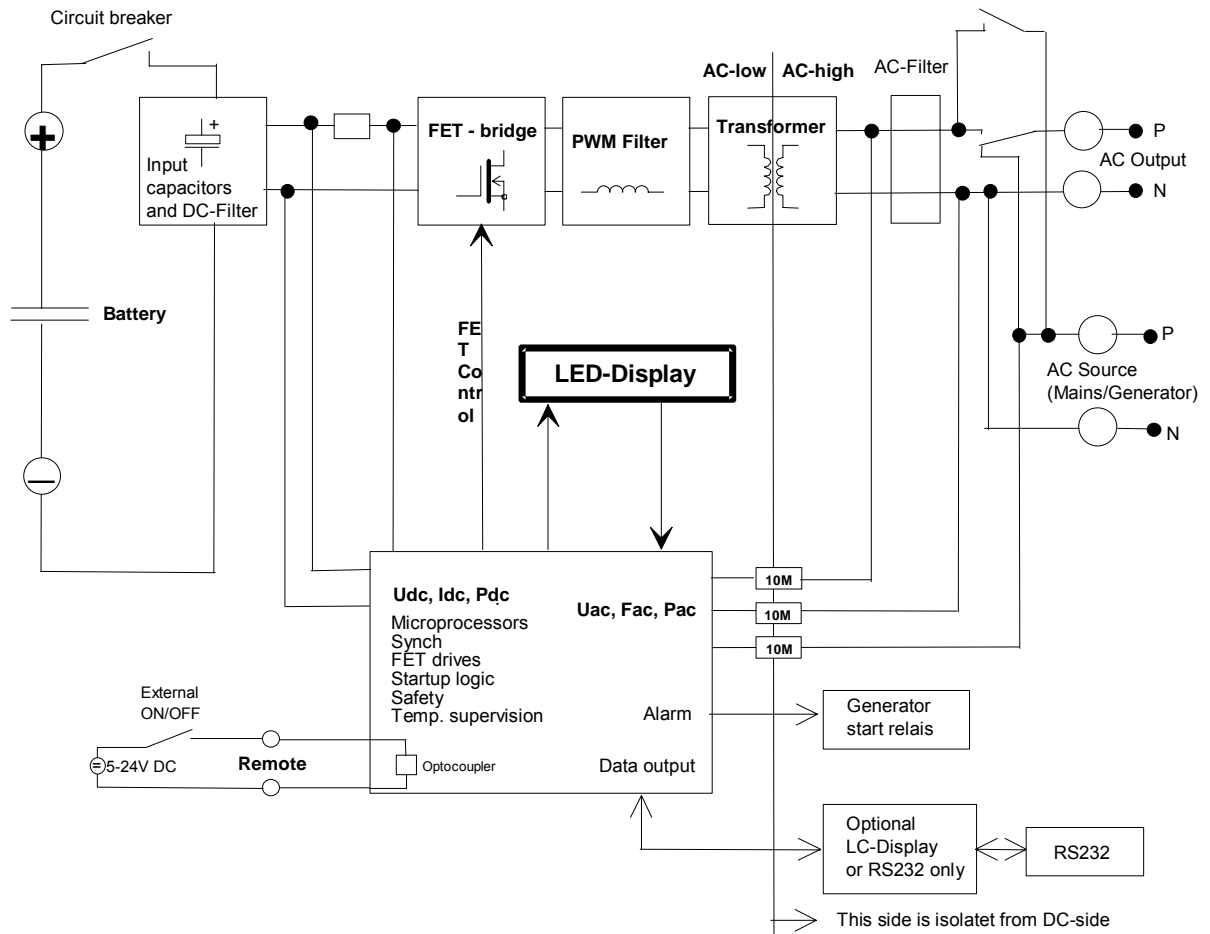

Time to cut-off while overload operation

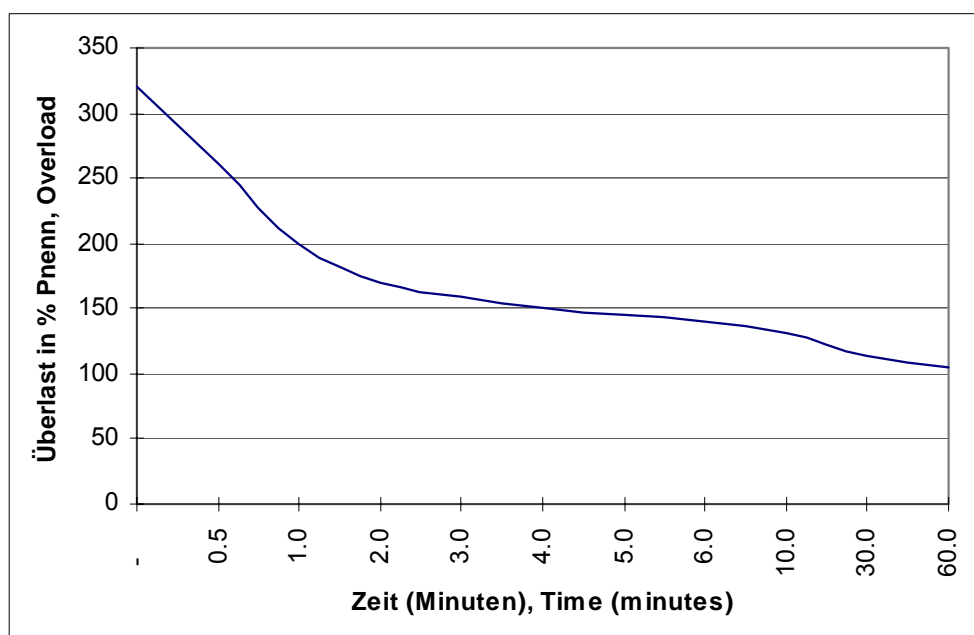

Installation

ALL WORKS MUST BE CARRIED OUT BY A LICENCED AND QUALIFIED TRADESPERSON

Check for compatibility of DC and AC voltage on compliance plate.

The inverter should be placed on a dry (humidity less than 95%, not condensing) place. Temperature range of the inverter is from -25°C to 50°C .

Short distance to batteries is desirable, however, electronic devices like inverters should not be exposed to corrosive gas of lead acid batteries.

DC cables should be protected by an earthed metal conduit against fire and interference. Allow sufficient space for cooling around the inverter (minimum 100mm)

Battery capacity should be adequate for the size of the charger; e.g. 400Ah for the 1300VA and 800Ah for the 2200VA.

When batteries are connected in parallel the inverter/charger unit should be installed diagonal for evenness of the discharge of the batteries.

With the connection of the inverter/charger other appliances **must not** be connected to the batteries in order to protect the battery.

A separate DC circuit breaker has to be installed directly at the batteries.

Connecting the AC load:

Switch OFF the unit's DC breaker.

ATTENTION - Be aware that input capacitors can remain charged even after the inverter is switched off and the removal of the DC input leads.

Connect the AC load at the terminals P1,N1,E1.

WARNING Do not connect the AC source there!!

AC circuit breaker has to be installed in the system and protection against lethal accidents should be considered.

Connecting an external ON/OFF remote control switch:

At clamp 1 and 2 (remote) the inverter/charger unit can be installed permanently for a voltage of between 5V and 24V independent of the poti code (S1) no matter what voltage polarity. With the voltage of between 5V and 24V the unit is permanently ON, if there is no voltage the unit is switched OFF or in stand-by. (depending on poti S1)

S1 OFF (anti-clock-wise)	voltage clamp 1,2=0V	unit=OFF
S1 OFF	voltage clamp 1,2=5-24V	unit= ON
S1 stand-by (01-98)	voltage clamp 1,2=0V	unit= stand-by
S1 stand-by (01-98)	voltage clamp 1,2=5-24V	unit= ON

Diagram for electrical connection

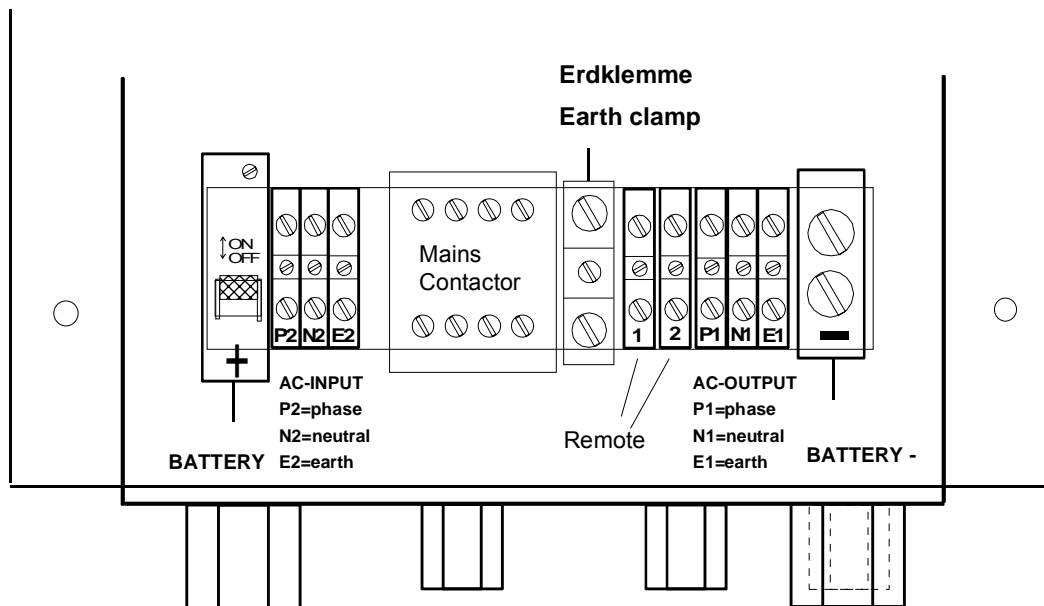

Warning! Do not connect mains/generator power to AC-output (P1,N1) of the inverter!

Connecting the batteries

Extrem care has to be taken for connecting the batteries as mistakes may damage the inverter/charger or the batteries!

Cable size should be at least 50mm². Observe right polarity. Wrong polarity can damage the inverter/charger.

Earthing

ATTENTION The unit is not internally earthed. When earthing the system on the + (positiv) the DC breaker must be connected on -(negativ).

Correct earthing is strongly advised, e.g. a 25mm² cable at the building earth. The AC output is neither with phase nor with zero earthed.

Connecting generator or grid

Generator or grid have to be connected to clamp P2, N2, E2. Before connecting make sure that the AC side (generator or grid) is switched off.

Connecting the auto start of the generator

With an auto start device at the generator the inverter/charger unit will automatically start the generator.

At clamp C/D or E/F of the filter circuit board a relay for generator start or for alarm can be installed. The switch capacity is there 2A/30V. The contacts will close in case of failures (low battery, overload, overtemperature etc.) and will remain closed for a minimum time of 5 minutes. The maximum running time ends latest 8 hours after achiving float voltage.

Connecting the temperature sensor

The temperatur sensor for the batteries is connected at clamps A/B. The unit will sense automatically whether the temperatur sensor is connected or not. As the unit compensates the charge voltage it is necessary that indeed the temperatur of the batteries is measured and not accidentally the ambient temperature! Best connect the sensor at a battery pol not to damage the batteries.

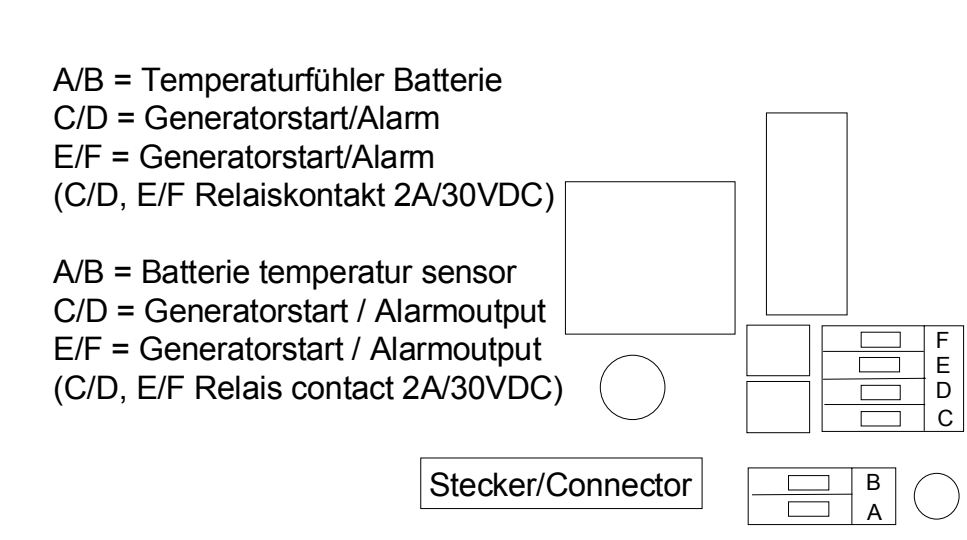

Reviewing the installation:

- Potentiometer S1 OFF (all anti clock wise)
- *When using the remote panel the potentiometer Off-Level-ON to the OFF position*
- Switch on the DC circuit breaker
- The unit is now ready for operation
- If necessary the parameter can now be adjusted. (reference is made to Factory Settings)

Operation hints

The DC circuit breaker should always be in the ON position. The unit is protected against DC-overvoltage, short circuit on the AC side and contains a load depending undervoltage control. The voltage for low battery cut-off is adjustable at the poti 1 of the main electronic board.

ATTENTION: Extrem high DC overvoltage can destroy the unit despite the protection circuitry.

IMPORTANT: In case the circuit breaker on the unit switches off any load has to be switched OFF as well before switching ON the circuit breaker.

Explanations to charge codes

Code IU

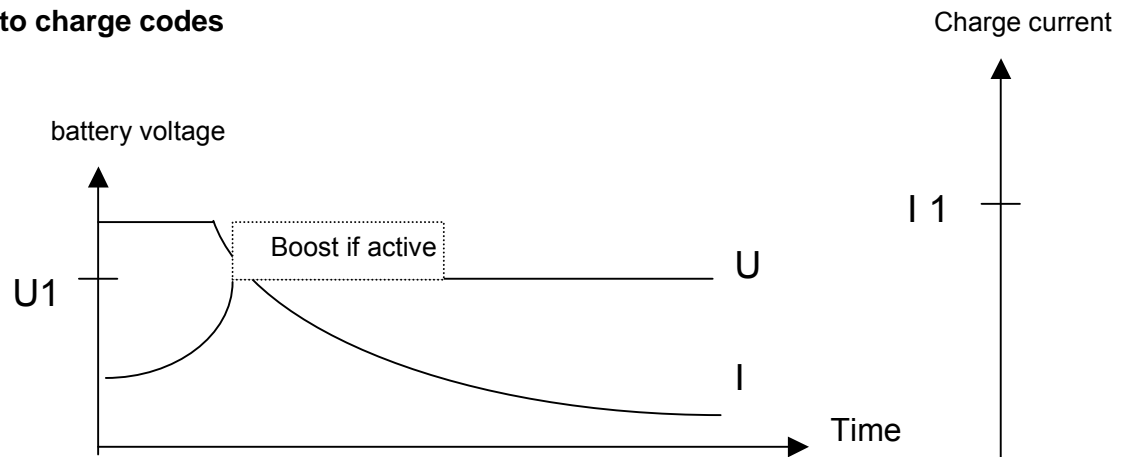

U1 Float voltage, recommended maximum 2.4V/Cell
 Adjustment range 2.1V/Cell - 2.5V/Cell
 I1 Maximum charge current, recommended 10 - 30A/100Ah
 The IU code is suitable for repeated or continue charging.

Code IUoU

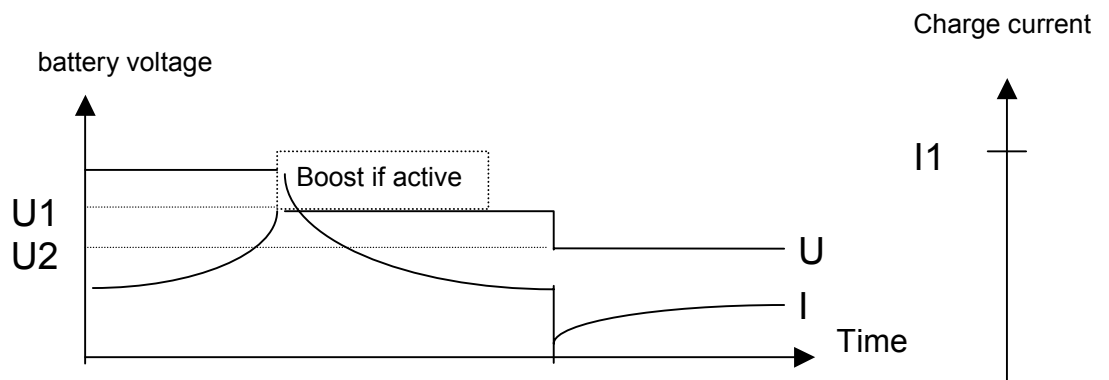

U1 Float voltage, recommended maximum 2.4V/Cell
 Adjustment range for float voltage 2.1V/Cell - 2.5V/Cell
 U2 continue charge voltage minimum 2.3V/Cell
 U2 is automatically 0.1V/Cell lower as adjustable U1
 I1 maximum charge current, recommended 10 - 30A/100Ah

The IUoU code is particular suitable for automatic fast charging of the batteries and for maintaining the charged up level. Charging is similar as with IU code but when batteries are at full charge level the unit switches to maintaining charge.

Short codes

U= constant voltage line
 I = constant current line
 o= automatically code jump

The series is according to the charging course

Explanation to the generator or alarm contact

A = Inverter shows error, e.g. overtemperature LED on.

B = Inverter is in operation mode, e.g. LED blank

C = Start charge with U code (reaching float voltage)

1 = Inverter temperatur

2 = Inverter output (without grid/generator)

3 = Generator relay (without grid/generator)

4 = Generator relay (generator ON)

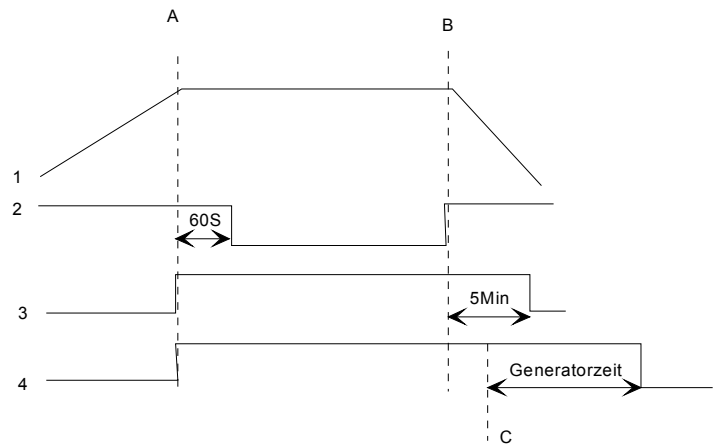

This contacts close at:

Lobattery	= Inverter indicates low battery level
Overtemperature	= Inverter indicates overtemperature
Overload	= Inverter indicates overload
AC low	= Inverter indicates low AC voltage

The contacts close also if load exceeds 80% of the nominal power for more than 5 minutes.

Note: Generatortime (Generatorzeit) in the above diagram is adjustable with potentiometer Nr:5. This time starts when the float voltage of the battery is reached.

Potentiometers on the main board

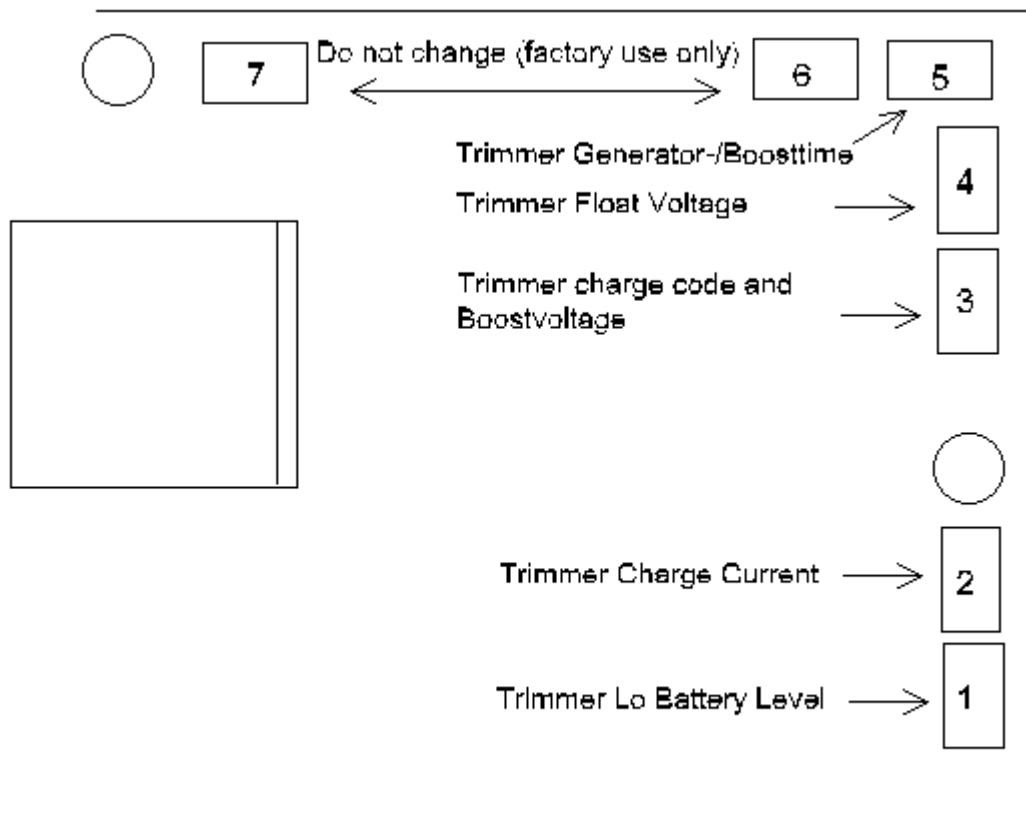

Factory settings

The TOP CHARGE inverter/charger has the following factory setting and can be adjusted:

	<u>Factory setting</u>	<u>Adjustable to:</u>	<u>Poti number</u>
Low Battery level	1.75V per cell	1.66V - 1.99V	1
Charging Code	50% I _{max} . IU	0 - 100% IU/IUoU	2 3
Boostlevel	0V	0-1.8V higher than float	3
Float level	2.25V per cell	2.08V - 2.5V per cell	4
Generator/Boost time	0 minute	0-255 minutes	5

Changing the levels - using the remote display

1. Switch off inverter (turn potentiometer all anti-clock-wise)
2. Choose menu for the desired level
3. Change poti for the new level (display delay of 2seconds)

<u>Indicator</u>	<u>Description</u>	<u>Poti number</u>
ASP TOP CHARGE V1.5 2.2KVA/24	Type of inverter Software version, Nominal power and voltage	
Inverter OFF	Inverter mode	
Set Icharge <i>91A</i>	Display of adjusted charge current	2
Charge Mode IU	Charging code set	3
Set Boost <i>+0.0V</i>	Higher voltage boost mode (Vfloat+higher boost=Boostvoltage)	3
Set B&G Time <i>000</i>	Boost time / Generator time in minutes set	5
Set Vlobat <i>21.0V</i>	Lo battery cut-off voltage set	1
Vbatt=26.32Volt	Actual battery voltage	
Set Vfloat <i>27.03V</i>	Float voltage set	4

All above figures printed in *italic style* can be adjusted.

Changing levels - using a computer

Any PC, Laptop, PSION etc. is suitable to choose menus. Any software as Hyperterminal, Procomm etc. can be used to display the data's.

The code for the communication software:

Baud rate	4800
Data bits	8
Parity	N
Stopbits	1

The computer read out is:

<u>Display</u>	<u>Description</u>	<u>Poti number</u>
\$0 ASP TOP CHARGE	Inverter model	
\$1 V2.4 2.2KVA/24V	Software version, power rating, voltage	
\$2 INVERTER OFF	Inverter operation	
\$3 Set Icharge 45A	Charge current set	2
\$4 CHARGE MODE IU	Charge mode set	3
\$5 Boost +0.0V 3	Boost level set	
\$6 Set B&G Time 000	Boost time/ Generator time in minutes set	5
\$7 Set Vlobat 21.0V	Low battery level set	1
\$8 Vbatt=24.89V	Actual battery voltage	
\$9 Set Vfloat 27.0V	Float level set	4
\$N NORMAL OPERATION	Operation mode / failure message	

All above figures printed *in italic style* can be adjusted.

LED - Display - STAND BY adjusting

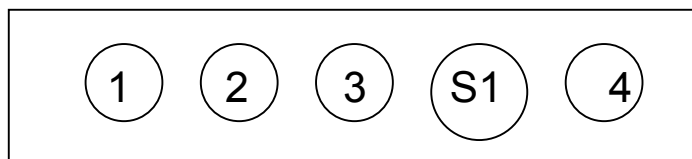

LED (1) LOBAT

DC voltage outside tolerance. After 60s the unit will switch OFF (LED flashes). **Attention!** The unit will restart automatically as soon as DC-voltage is within limits again. In case of undervoltage the battery should be charged or checked for defect.

LED (2) OVERTEMP

Overtemperature of the inverter. After 60s of overtemperature the unit will switch OFF. **Attention!** The unit will restart automatically after cooling down.

LED (3) AC-OUTPUT

LED green = unit ON

LED green flashing = stand-by

Hint: This LED is flashing orange shortly prior to going in stand-by; adjust stand-by level to your lowest load!!

LED red= voltage is outside tolerance (e.g. short circuit at AC output). The unit will switch OFF and LED red is flashing. **Attention!** After 20s the unit will switch ON again automatically.

STDBY-ADJUST(S1)

Potentiometer for adjusting stand-by level range of between 0 - 99W, for continues mode or switched OFF mode.

- Potentiometer
- turned all anti-clock wise = unit is switched OFF.
 - turned clock-wise = switch ON level lower.
 - turned all clock wise = Unit is in continues mode.

With the use of the optional remote display panel the potentiometer (S1) has to be in OFF-position (fully anti clock wise) in order for the remote control to work.
 Stand-by level at 00 = unit is in continues mode
 Stand-by level at 99 = unit is switched off.

LED (4) Charge

Red light indicates that the batteries are charge with code I. Orange flashing indicates charging in float mode.

IMPORTANT

After overload or other wrong parameters (e.g. overtemperature) the TOP CHARGE unit will try every 30 seconds to automatically switch ON. Automatic switch ON time may vary between few seconds and some hours. The unit therefore has to be disconnected from the batteries during electrically manipulations.

Function of the stand-by program

In stand-by the inverter automatically senses whether any connected appliances requires power to be switched on. In the stand-by mode the unit's own power consumption is approximately 2W. Every 800ms the unit measures the output requirements and switches ON when the requirement is above the level adjusted to. If during a time of 10s no power is required the unit goes back in stand-by. The level of the stand-by can slightly vary depending on battery voltage and temperature. (approx. +/-2W)

Small loads may cause the inverter switch ON and OFF, however, many appliances require small amounts of power even when switched off thus the inverter may not switch to stand-by altogether.

The optional remote display panel

The remote display can be connected to the inverter with a standard 9pol (1:1) cable. The cable can be up to 60m long. Power is supplied via the same cable but with galvanic separation. The display does not require a battery or grid plug.

On the 2x16 digit display with backlight you can have the readout of all relevant data's:

Three different modes are available:

- Inverter mode No grid connected or generator not in use
- Charger mode Grid connection or generator auto start
- OFF mode Inverter is switched off

The potentiometer OFF-LEVEL-ON mode provides:

Potentiometer in full anti-clockwise position	= Stand-by level 99	= Inverter
OFF		
Potentiometer in full clockwise position	= Stand-by level 00	= Inverter
ON		
Potentiometer in between position	= Stand-by level 01-98	= Inverter
Stand-by		

In order to ensure proper function of the remote control the poti S1 at the inverter has to be in the OFF position.

At the RS232 output of the Display a computer can still be connected with a cable not more than 30 meters.

- Toggle switch
- 02 seconds = Boost activ
 - 10 seconds = Manual generator start
 - 20 seconds = All reset

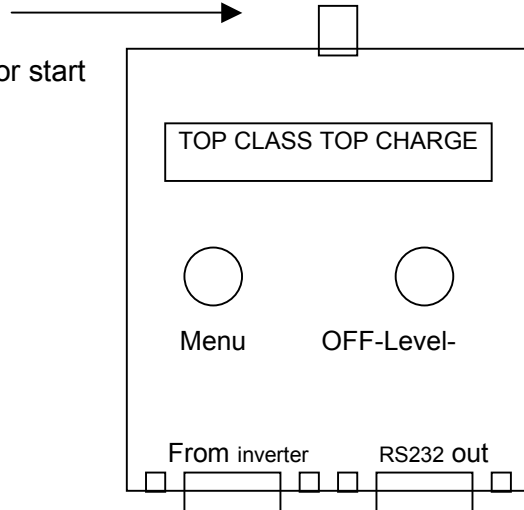

Explanations to the menues

Inverter switched OFF

Indicator	Description
ASP TOP CHARGE V2.4 2.2KVA/24V	Type of inverter Software version, nominal power and voltage
Inverter OFF Set Icharge 54A	Inverter mode Charge current set
Charge Mode IU Set Boost +0.0V	Charging code set Higher voltage boost level set (Vfloat+higher boost=Boostvoltage)
Set B&G Time 000 Set Vlobat 21.0V	Boost time and generator time in minutes set Lo battery cut-off voltage set
Vbatt=26.32Volt Set Vfloat 27.03V	Actual battery voltage Float voltage set

Display RS232 in OFF mode

Display number	Description	Poti
\$0 ASP TOP CHARGE	Inverter type	
\$1 V1.5 2.2KA/24V	Software version, nominal power and voltage	
\$2 Inverter OFF	Inverter mode	
\$3 Set Icharge 54A	Charge current set	2
\$4 Charge Mode IU	Charge code set	3
\$5 Boost +0.0V 3	Boost level set	
\$6 Set Boost Time 000	Boost-/Generator time in minutes	5
\$7 Set Vlobat 21.0V	Low battery level set	1
\$8 Vbatt= 24.89V	Actual battery voltage	
\$9 Set Vfloat 27.03V	Float voltage set	4
\$N Normal operation	Operation mode / failure message	

All above figures printed in *italic style* can be adjusted.

Inverter operation

Vbattery = 27.5Vdc	Actual battery voltage
Ibat = 008A invert	Actual battery discharge current
Output = 230Vac	Output voltage inverter
Pac = 0199W invert	Output power and inverter mode
0---%Pnac---200 *****	Output scale in % nominal Actual output AC-power in graph
Standby level 00	Stand-by level set (99=OFF, 00=ON)
Tintern=056cels	Inverter temperature
NORMAL OPERATION	Inverter mode or error display
9999s to cutoff	Time to switch OFF (9999s=infinite)

Readout RS 232 in inverter mode:

```

$0 Vbattery = 25.3Vdc
$1 Ibat = 000A invert
$2 Output = 226 Vac
$3 Pac=0000W invert
$4 0---%Pnac ---200
$5
$6 Standby Level 00
$7 T intern= 036cels
$8 NORMAL OPERATION
$9 9999s to cutoff
$N NORMAL OPERATION

```

Remark: In case of error position \$8-N will indicate the error message in true text.

Example:

```

OVERLOAD           Inverter in overload
0180s to cutoff    Inverter will switch off in 180 seconds

```

Charge operation

Vbattery=27.5Vdc Charge V float	Actual battery voltage Actual charge mode
Mains = 213V Icharge= 46A	Actual grid/generator voltage Battery charge current
Pac = 2033W charge Tintern=054cels	Charge input power and inverter mode Inverter temperature
Tbatt = 18cels 0001 minute float	Battery temperature Time since reaching float level
CHARGE MODE IU TIMERS G050 B120 inactive,	Charge mode set Remaining generator-/boost time (B000= Boost function G/B100=Generator stop and and boost end in 100minutes)

Readout RS 232 while charging:

\$0 Vbattery = 26.9Vdc
 \$1 Charge V float
 \$2 Mains = 221Vac
 \$3 I charge =44Adc
 \$4 Pac=1272W charge
 \$5 T int= 034cels
 \$6 Tbatt = ----cels
 \$7 0000minute float
 \$8 CHARGE MODE IU
 \$9 BOOST TIMER 000

Activating boost mode

Press toggle switch at the remote display for 2 seconds. The display shows 16xB to confirm the activated boost mode. In the menu the remaining boost time will be displayed.

Manual Generator start

Press the toggle switch at the remote display for 10 seconds. The display first shows 16xB (boost active) and 16xG (Generator will start).

Reset of Boost and Generator

To switch off the generator and deactivate the boost you can press the toggle switch at the remote display for 20 seconds. The display confirm the new input by displaying 16xC. The generator will stop and boost is no longer activated.

Technical data's

TOP CLASS "COMBI"	TCNL13/12	TCNL22/24
Inverter		
Rated Voltage UDC _{IN}	12V	24V
Input Voltage Range	10.5 ... 16.0V DC	21.0 ... 32.0V DC
Dynamic Low Voltage Cut Off (depending on load)	10.5 ... 9.0V DC	21.0 ... 18.0V DC
Rated current IDC _{IN}	125A	100A
Current IDC _{IN} max.	350A	290A
Rated Power P ₁₀ (10 min at T _A =20°C)	1400VA	2900VA
Rated Power P ₃₀ (30 min at T _A =20°C)	1300VA	2200VA
Continuous Power P _D	1000VA	2000VA
Rated Output Voltage UAC _{OUT}	230V AC, ± 2% (short circuit proof)	
Output Frequency	50Hz, ± 0.5% (true sinewave)	
Rated Output Current IAC _{OUT}	5.7A	9.7A
Short Circuit Current IAC _K (max. 0.5s)	16A	25A
Allowable CosPhi	0.3 ... 1	
Efficiency Factor max.	92%	93%
Adjustable Standby Level (logarithmic)	4 ... 40W	
Consumption Standby/OFF	ca. 1W (Test impulse every 800ms) / 0W	
Consumption 230V AC OK	11W	16W
Synchronization	fully automated synchronization to Grid or Generator	
Reset after Short Circuit	every 60s	
Reset after Overload	every 60s	
Reset after Overtemperature	automatically after reaching semiconductor temp. +45°C	
Reset after Battery failure	automatically after reaching UDC _{IN}	
Battery-Charger		
Max. cont. Charge Power	1300W	2200W
Charge algorithm	IoU or IUoU selectable	
Charging Current (adjustable)	0 ... 90A	0 ... 90A
Efficiency Factor max.	88%	91%
CosPhi	≈1	
Input Voltage Range	196 ... 245V AC	
Input Frequency Range	45 ... 55 Hz	
Temperature compensation (sensor included)	-10mV/K per Cell (0 ... 35°C)	
Float Voltage adjustable	12.5 ... 15.0V	25.0 ... 30.0V
General data		
Ambient Temperature range	-25°C ... +50°C (max. 95% rH, not condensing)	
DC- Breaker / fuse	no	125A
Remote control ON / OFF	yes	yes
Status indication	LED / (optional LCD)	LED / (optional LCD)
Automatic Transfer Switch	40A / 250V	
Transfer Time	typ. 20ms / max. 50ms	
Relay Contact for Generator start up	2A / 30V DC (isolated)	
Generator Time	0 ... 255 min	
Toroidal Transformer (galvanically isolated)	IEC742, VDE0551	
Temperature and Load controlled fan	ON 55°C / OFF 45°C, P _D >80%	
RS-232 Interface	yes	yes
Dimensions (L x W x H)	375 x 181 x 375 mm	456 x 320 x 211 mm
Dimensions optional remote indication (L x W x H)	110 x 90 x 30 mm	
IP Protection	IP20	
Standards	CE	
Weight	17 kg	21 kg
Warranty	2 years	

Technical changes reserved (02/2003)

CE-Declaration of conformity

We declare under our sole responsibility that this product is in conformity with the following standards or standardization documents: EN 50081-1 Generic 92, EN50082-1 Generic 92



A. Rüegg
ASP AG
Geschäftsleitung

Short form of manual for TOP CLASS TOP CHARGER

1. Turn potentiometer on the front panel all anti-clock-wise (inverter OFF)
2. Connect remote display panel if applicable
3. Connect computer and RS232 at the output if applicable. Communication software Procomm or Hyperterminal (4800,8N1)
4. Turn potentiometer at the remote display to OFF (OFF-Level-ON)
5. Connect sensor at the batteries and at the filter print with clamp A,B (as shown on page 9 of manual)
6. Connect load at the clamps P1,N1,E1 (include AC-breaker)
7. Connect external relay from generator auto start with clamp C/D; EF can be for alarm output if applicable
8. Connect AC generator or grid with clamps P2,N2,E1 (generator/grid switched OFF)
9. Check the DC voltage at the input clamp of the inverter
10. Switch ON DC breaker
11. Operation modes can now be adjusted if desired (re page 12ff of manual)
12. Inverter is now ready for operation!
13. for charging operation switch on grid or generator

ATTENTION! AC-input and AC-output must not be mixed up!!

Connections diagram

