



INSTALLATION MANUAL

FOR THE

KC-SERIES

OF

SOLAR PHOTOVOLTAIC POWER MODULES

Please read this manual carefully before installing the modules.

KYOCERA

6C-203828-1

1. INTRODUCTION

As the world leader in development and application of high technology ceramic/silica materials, Kyocera offers a wide range of highly efficient and reliable crystalline silicon solar photovoltaic (PV) power modules. Kyocera began to extensively research PV technology in 1975 and commenced manufacturing operations in 1978. Since then, Kyocera has supplied millions of cells and modules throughout the world. With years of experience and state-of-the-art technology, Kyocera provides the highest quality PV power modules in a range of sizes designed to meet the requirements of the most demanding energy and power users worldwide.

2. POWER MODULES

Kyocera power modules consist of a series of electrically interconnected crystalline silicon solar cells. Which are permanently laminated within a pottant and encapsulated between a tempered glass cover plate and a back sheet. The entire laminate is secured within an anodized aluminum frame for structural strength, ease of installation, and to protect the cells from the most severe environmental conditions.

3. APPLICATIONS

Kyocera modules are a reliable, virtually maintenance-free direct current (DC) power source, designed to operate most efficiently in sunlight. Kyocera modules are ideal to power remote homes, recreational vehicles, water pumps, telecommunication systems and many other applications either with or without the use of storage batteries.

4. WARNINGS

Solar modules generate electricity when exposed to light. Arrays of many modules can cause lethal shock and burn hazards. Only authorized and trained personnel should have access to these modules. To reduce the risk of electrical shock or burns, modules may be covered with an opaque material during installation to avoid shocks or burns. Do not touch live terminals with bare hands. Use insulated tools for electrical connections.

PERMIT

- Before installing your solar system, contact local authorities to determine the necessary permit, installation and inspection requirements.

INSTALLATION AND OPERATION

- Systems should be installed by qualified personnel only. The system involves electricity, and can be dangerous if the personnel are not familiar with the appropriate safety procedures.
- Do not step on the module.
- Although KYOCERA modules are quite rugged, the glass can be broken (and the module will no longer work properly) if it is dropped or hit by tools or other objects.
- Sunlight shall not be concentrated on the module.
- The module frame is made of anodized aluminum, and therefore corrosion can occur if the module is subject to a salt water environment with contact to a rack of another type of metal.(Electrolysis Corrosion) If required, PVC or stainless steel washers can be placed between the solar module frame and support structure to prevent this type of corrosion.
- The solar module frame must be attached to a support structure using ¼" or M6 stainless steel hardware in a minimum of four (4) places symmetrical on the solar module. The stainless steel hardware used for securing the module frame should be secured with an applied torque of 6 foot-pounds (8 Newton-meters).
- Module support structures that are to be used to support Kyocera Solar modules should be wind rated and approved for use by the appropriate local and civil codes prior to installation.

GROUNDING

- All module frames and mounting racks must be properly grounded in accordance with local and national electrical codes.

INSPECTION

- Follow the requirements of applicable local and national electrical codes.

BATTERY

- When solar modules are used to charge batteries, the battery must be installed in a manner which will protect the performance of the system and the safety of its users. **Follow the battery manufacturer's guidelines concerning installation, operation and maintenance recommendations.** In general, the battery (or battery bank) should be away from the main flow of people and animal traffic. Select a battery site that is protected from sunlight, rain, snow, debris, and is well ventilated. Most batteries generate hydrogen gas when charging, which can be explosive. Do not light matches or create sparks near the battery bank. When a battery is installed outdoors, it should be placed in an insulated and ventilated battery case specifically designed for the purpose.

5. SITE SELECTION

In most applications, KC modules should be installed in a location where they will receive maximum sunlight throughout the year. In the Northern Hemisphere, the modules should typically face south, and in the Southern Hemisphere, the modules should typically face north. Modules facing 30 degrees away from true South (or North) will lose approximately 10 to 15 per cent of their power output. If the module faces 60 degrees away from true South (or North), the power loss will be 20 to 30 per cent. When choosing a site, avoid trees, buildings or obstructions which could cast shadows on the solar modules especially during the winter months when the arc of the sun is lowest over the horizon.

6. MODULE TILT ANGLE

Kyocera solar modules produce the most power when they are pointed directly at the sun. For installations where the solar modules are attached to a permanent structure, the solar modules should be tilted for optimum winter performance. As a rule, if the system power production is adequate in the winter, it will be satisfactory during the rest of the year. The module tilt angle is measured between the solar modules and the ground (Figure 1). Refer to Table 1 for the recommended module tilt angle at your site.

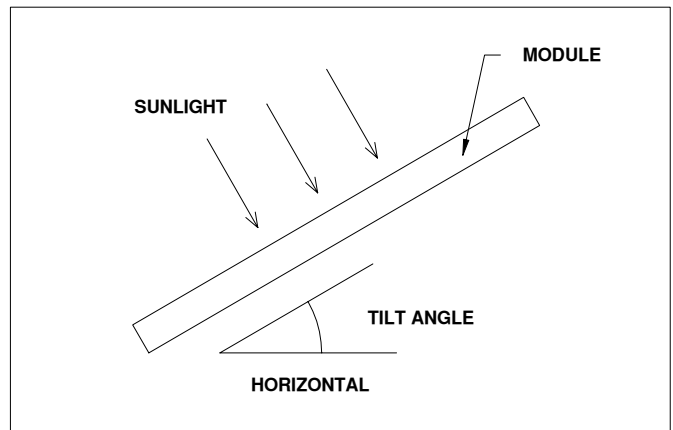

Figure 1. Module Tilt Angle

Table 1. Recommended Tilt Angles for Fixed Systems—Based on Winter Performance

SITE LATITUDE IN DEGREES	FIXED TILT ANGLE
0° TO 15°	15°
15° TO 25°	SAME AS LATITUDE
25° TO 30°	LATITUDE + 5°
30° TO 35°	LATITUDE + 10°
35° TO 40°	LATITUDE + 15°
40° +	LATITUDE + 20°

7. INSTALLING KC MODULES

The frame of each module has 0.28" ϕ diameter (7 mm) mounting holes (Refer to Module Mounting Specifications). These are used to secure the modules to the supporting structure. An example of a ground mounted structure is shown in Figure 2. The four holes close to the corners of the module are most often used for attachment. Refer to the Mounting Specification Specifications for the position of these holes. Clearance between the module frame and the mounting surface may be required to prevent the junction box from touching the surface, and to circulate cooling air around the back of the module. If the modules are to be installed on the roof or wall of a building, the standoff method or the rack method is recommended.

STAND-OFF METHOD: The modules are supported parallel to the surface of the building wall or roof. Clearance between the module frames and surface of the wall or roof is required to prevent wiring damage and to allow air to circulate behind the module.

The recommended stand-off height is 4.5 in. (about 115 mm) If other mounting means are employed, this may affect the Listing For Fire Class Ratings.

RACK: The supporting frame is used to mount modules at correct tilt angles. The modules are not designed for integral mounting as part of a roof or wall. The mounting design may have an impact on the fire resistance.

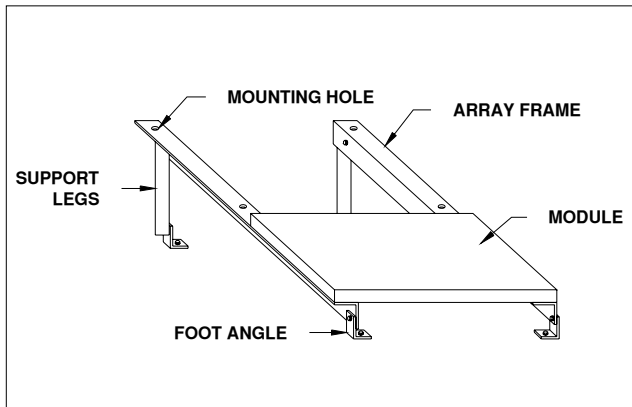

Figure 2. Basic Rack or Standoff Mounting Structure

8. MODULE WIRING

As shown in Module Mounting Specifications, all of the KC modules utilize the Type G junction box except the KC85T, KC85TS, KC125TM, KC130TM modules which utilize the Type M junction box (see J-box details). This junction box, located on the back side of the module, is weatherproof and is designed to be used with standard wiring or conduit connections. Kyocera recommends that all wiring and electrical connections comply with the 2002 National Electrical Code (NEC). A cable clamp with a minimum rating of IP65 must be used to maintain the weatherproof integrity of the junction box. Bypass diodes are preinstalled at factory

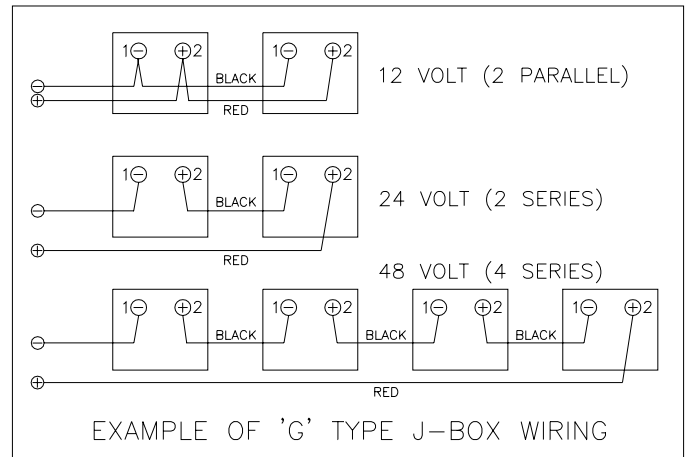
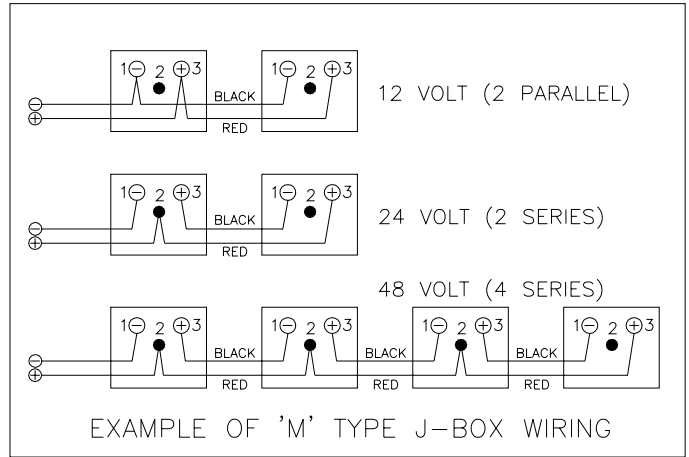

Figure 3. Standard Wiring Examples

To wire Kyocera modules:

- A. Determine the nominal system array voltage of your system. Each panel is equivalent to a 12 VDC nominal block. Standard array voltages 12, 24 and 48 volt are shown as examples in Figure 3.
- B. Open the "G" or "M" box cover by loosening the screws in the cover.
- C. The wire used to interconnect the solar modules may be single or two conductors, from 14 AWG (2.08 mm²) up to 10 AWG (5.26 mm²) gauge stranded copper wire, in a "SUNLIGHT RESISTANT" jacket UF cable. This cable is suitable for applications where wiring is exposed to the direct rays of the sun. The maximum and minimum outer diameters of the cable that may be used with the cable connector are 8 mm and 6 mm respectively (Figure 4).
- D. Using a flat blade screwdriver, remove only the appropriate "KNOCK-OUTS" from the sides of the "G" or "M" box.
- E. Route wires through the knock-outs and clamps refer to installation example (see Figure 5).
- F. Gently hand tighten the terminal screws with cross tip (Phillips head) screwdriver. Do not over tighten, as the terminal can be damaged.
- G. The output wiring from the final module is generally run to a separate array junction box. In commercial system, this wiring from the array box to the next component (i.e. fuse box. or charge regulator, etc.) is generally run in conduit. The maximum electrical rating of an acceptable series fuse is 6~12 amperes.
- H. After checking that module wiring is correct, close and secure all the junction boxes. Use a Phillips head screw driver to secure all screws on the junction box cover to ensure a waterproof seal.

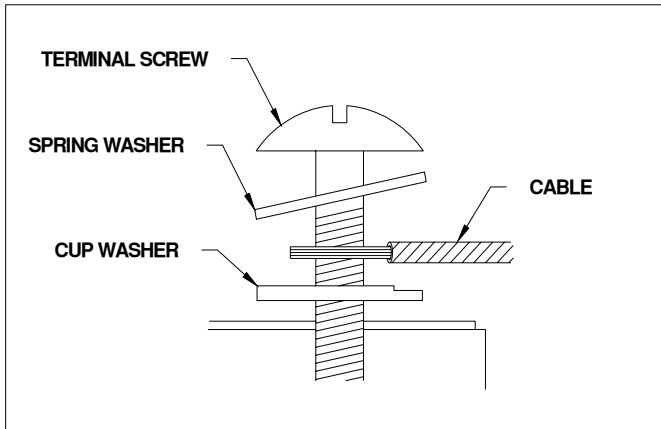

Figure 4. Ring or Spade Terminal Connectors

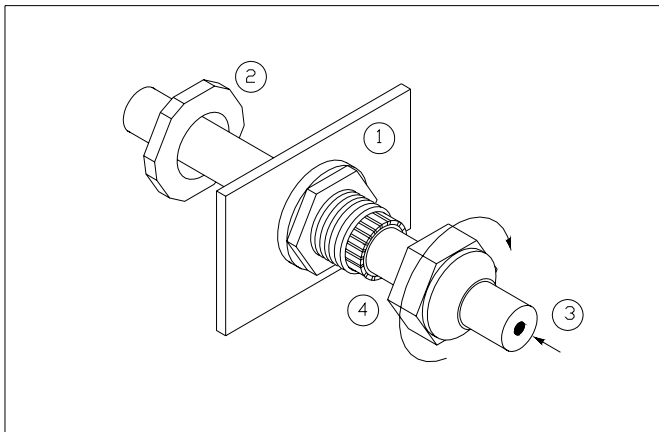

Figure 5. Installation Example of Cable Clamp

9. GROUNDING

We recommend you attach all module frames to an earth ground. Attach a separate ground wire to one of the holes marked 'ground' on the module frame with a screw and bonding or external tooth washer. This is to ensure positive electrical contact with the frame. The racks must also be grounded unless they are mechanically connected by nuts and bolts to the grounded modules. The array frame shall be grounded in accordance with NEC Art 250.

10. BLOCKING DIODES

Blocking diodes are typically placed between the battery and the PV module output to prevent battery discharge at night. Kyocera modules are made of polycrystalline cells with high electrical "back flow" resistance to nighttime battery discharging. As a result, KYOCERA modules do not contain a blocking diode when shipped from the factory. Most PV charge regulators do have nighttime disconnect feature, however.

11. BYPASS DIODES

Partial shading of an individual module in a 12 volt or higher source circuit string (i.e. two or more modules connected in series) can cause a reverse voltage across the shaded module. Current is then forced through the shaded area by the other modules.

When a bypass diode is wired in parallel with the series string, the forced current will flow through the diode and bypass the shaded module, thereby minimizing module heating and array current losses.

For 12-volt systems and higher: Each module junction box has a diagram illustrating the proper orientation of the bypass diode installed between two of the terminal screws. When individual series strings of solar modules are connected together in parallel, bypass diodes should be used in each modules junction box.

Diodes that are used as bypass diodes must:

- Have a Rated Average Forward Current [$I_{F(AV)}$] **Above** maximum system current at highest module operating temperature.
- Have a Rated Repetitive Peak Reverse Voltage [V_{RRM}] **Above** maximum system voltage at lowest module operating temperature.

12. MAINTENANCE

Kyocera modules are designed for long life and require very little maintenance. Under most weather conditions, normal rainfall is sufficient

to keep the module glass surface clean. If dirt build-up becomes excessive, clean the glass surface only with a soft cloth using mild detergent and water. **USE CAUTION WHEN CLEANING THE BACK SURFACE OF THE MODULE TO AVOID PENETRATING THE PVF SHEET.** Modules that are mounted flat (0° tilt angle) should be cleaned more often, as they will not "self clean" as effectively as modules mounted at a 15° tilt or greater. Once a year, check the tightness of terminal screws and the general condition of the wiring. Also, check to be sure that mounting hardware is tight. Loose connections will result in a damaged module or array.

13. SPECIFICATIONS

The electrical and physical specifications can be found at the end of this document (Table2) .

NOTES

- The electrical characteristics are indicated values of P_{max} under standard test conditions (irradiance of $1KW/m^2$, AM 1.5 spectrum, and cell temperature of $25^\circ C$).
- Under certain conditions, a photovoltaic module is likely to produce more current and / or voltage than reported at standard test conditions. Accordingly, the values of I_{sc} and V_{oc} marked on this module should be multiplied by a factor of 1.25 when determining component voltage ratings, conductor ampacities, fuse sizes, and sizes of regulators which are connected to the PV output. Refer to Section 690-8 of the National Electrical Code for an additional multiplying factor of 1.25 which may also be applicable.

KYOCERA Solar Group Sales Office

■ KYOCERA Corporation

Corporate Solar Energy Group
6 Takeda Tobadono-cho Fushimi-ku, Kyoto 612-8501,
Japan
Phone : 81-75-604-3476
Fax : 81-75-604-3475
<http://www.kyocera.com/>

■ KYOCERA Solar Inc.

7812 East Acoma Drive, Scottsdale, AZ 85260, U.S.A.
Phone : 1-480-948-8003 or 1-800-223-9580
Fax : 1-480-483-6431
<http://www.kyocerasolar.com/>

■ KYOCERA Solar Pty Ltd.

Level 3, 6-10 Talavera Road
North Ryde NSW 2113, Australia
Phone : 61-2-9870-3948
Fax : 61-2-9888-9588
<http://www.kyocerasolar.com.au/>

■ KYOCERA Solar do Brasil Ltda.

Energia Renovavel LTDA, Rua Mauricio da Costa Faria,
85 22780-280 Recreio dos Bandeirantes
Rio da Janeiro, Brazil
Phone : 55-21-2437-8525
Fax : 55-21-2437-2338
<http://www.kyocerasolar.com.br/>

■ KYOCERA Fineceramics GmbH

Fritz Müller Strasse 107, D-73730 Esslingen, Germany
Phone : 49-711-9393-417
Fax : 49-711-9393-450
<http://www.kyocerasolar.com.de/>

■ KYOCERA Asia Pacific Pte Ltd.

298 Tiong Bahru Road, #13-03/05 Central Plaza
Singapore 168730
Phone : 65-271-0500
Fax : 65-271-0600
<http://www.kyocera.com.sg/>

■ KYOCERA (Tianjin) Sales & Trading Corp.

Binjiang International Hotel 1106,
105 Jianshe Road Heping Dist. Tianjin China
Phone : 86-22-2331-8590
Fax : 86-22-2330-6276

Table 2. Kyocera KC Series Module Specification

Electrical Characteristics: @ STC														
Model Number	KC40T		KC50T		KC65T		KC85T		KC85TS		KC125TM		KC130TM	
Rated Power, Watts (Pmax)	43	+ 15% - 5%	54	+ 15% - 5%	65	+ 10% - 5%	87	+ 10% - 5%	87	+ 10% - 5%	125	+ 10% - 5%	130	+ 10% - 5%
Open Circuit Voltage (Voc)	21.7		21.7		21.7		21.7		21.7		21.7		21.9	
Short Circuit Current (Isc)	2.65		3.31		3.99		5.34		5.34		8.00		8.02	
Voltage at Load (Vpm)	17.4		17.4		17.4		17.4		17.4		17.4		17.6	
Current at Load (Ipm)	2.48		3.11		3.75		5.02		5.02		7.20		7.39	
Maximum System Voc	600		600		600		600		600		600		600	
Factory Installed Bypass Diode (Qty)	Yes (2)		Yes (2)		Yes (2)		Yes (2)		Yes (3)		Yes (2)		Yes (2)	
Series Fuse Rating (Amps)	6		6		6		7		7		12		12	
Thermal Characteristics:														
Temp. coefficient of Voc (V/°C)	-8.21×10^{-2}		-8.21×10^{-2}		-8.21×10^{-2}		-8.21×10^{-2}		-8.21×10^{-2}		-8.21×10^{-2}		-8.21×10^{-2}	
Temp. coefficient of Isc (A/°C)	1.06×10^{-3}		1.33×10^{-3}		1.59×10^{-3}		2.12×10^{-3}		2.12×10^{-3}		3.18×10^{-3}		3.18×10^{-3}	
Temp. coefficient of Vpm (V/°C)	-9.31×10^{-2}		-9.32×10^{-2}		-9.32×10^{-2}		-9.32×10^{-2}		-9.32×10^{-2}		-9.31×10^{-2}		-9.31×10^{-2}	
Physical Characteristics:														
Model Number	KC40T		KC50T		KC65T		KC85T		KC85TS		KC125TM		KC130TM	
Length, Inches (mm)	20.7(526)		25.2 (639)		29.6 (751)		39.6(1007)		39.6(1007)		56.1(1425)		56.1(1425)	
Width, Inches (mm)	25.7(652)		25.7 (652)		25.7 (652)		25.7 (652)		25.7 (652)		25.7 (652)		25.7 (652)	
Depth (frame), Inches (mm)	1.42(36)		1.42 (36)		1.42 (36)		1.42 (36)		1.42 (36)		1.42 (36)		1.42 (36)	
Depth (including j-box), inches (mm)	2.1(54)		2.1(54)		2.1(54)		2.3(58)		2.3(58)		2.3(58)		2.3(58)	
Weight, Pounds (kg)	9.9(4.5)		11.0 (5.0)		13.2 (6.0)		18.3 (8.3)		18.3 (8.3)		26.9 (12.2)		26.9 (12.2)	
Mounting Hole Diameter inches (mm)	0.28" (7)		0.28" (7)		0.28" (7)		0.28" (7)		0.28" (7)		0.28" (7)		0.28" (7)	
Grounding Hole Diameter inches (mm)	0.28" (7)		0.28" (7)		0.28" (7)		0.28" (7)		0.28" (7)		0.28" (7)		0.28" (7)	
	Qty - 4		Qty - 4		Qty - 8		Qty - 8		Qty - 8		Qty - 8		Qty - 8	
	Qty - 2		Qty - 2		Qty - 2		Qty - 2		Qty - 2		Qty - 2		Qty - 2	

NOTES

- (1) Standard Test Conditions of irradiance of 1000 W/m², spectrum of 1.5 air mass, and cell temperature of 25 deg C.
- (2) Normal Operational Cell Temperature (NOCT) of 800 W/m², spectrum of 1.5 air mass, and cell temperature of 25 deg C.
- (3) See module drawing for mounting and grounding hole locations.

JUNCTION BOX
SEE DETAILS

φ"1" [TYP.]

GROUNDING HOLE MARKED

MODULE DIMENSIONS											
MODULE	J-BOX	DIM. A	DIM. B	DIM. C	DIM. D	DIM. E	DIM. F	DIM. G	DIM. H	DIM. I	
KC40T	TYPE G	20.71"	25.67"	24.13"	18.43"	0.77"	1.14"	-	18.42"	0.28"	
KC50T	TYPE G	25.16"	25.67"	24.13"	22.87"	0.77"	1.14"	-	22.87"	0.28"	
KC65T	TYPE G	29.57"	25.67"	24.13"	27.28"	0.77"	1.14"	9.49"	10.59"	0.28"	
KC85T	TYPE M	39.65"	25.67"	24.13"	37.36"	0.77"	1.14"	9.49"	20.67"	0.28"	
KC85TS	TYPE M	39.65"	25.67"	24.13"	37.36"	0.77"	1.14"	9.49"	20.67"	0.28"	
KC125TM	TYPE M	56.10"	25.67"	23.94"	53.82"	0.87"	1.14"	9.49"	37.13"	0.28"	
KC130TM	TYPE M	56.10"	25.67"	23.94"	53.82"	0.87"	1.14"	9.49"	37.13"	0.28"	

DIODE POSTS DO NOT USE

DIODE (6PL)

TERMINAL DESIGNATIONS

1: NEGATIVE POST
2: ISOLATED POST
3: POSITIVE POST

TYPE 'M' J-BOX

DIODE POSTS DO NOT USE

DIODE (9PL)

TERMINAL DESIGNATIONS

1: NEGATIVE POST
2: ISOLATED POST
3: POSITIVE POST

TYPE 'M' J-BOX (KC85TS)

DIODE POSTS DO NOT USE

DIODE (4PL)

TERMINAL DESIGNATIONS

1: NEGATIVE POST
2: POSITIVE POST

TYPE 'G' J-BOX

DIODE
SYMBOL