



## WAECO CoolMatic

### MDC-50, MDC-65, MDC-90, MDC-110

DE 6 **Kühlschrank**  
Bedienungsanleitung

EN 22 **Refrigerator**  
Instruction Manual

FR 37 **Réfrigérateur**  
Notice d'utilisation

ES 53 **Nevera**  
Instrucciones de uso

IT 69 **Frigorifero**  
Istruzioni per l'uso

NL 85 **Koelkast**  
Gebruiksaanwijzing

DA 100 **Køleskab**  
Betjeningsvejledning

SV 115 **Kylskåp**  
Bruksanvisning

NO 130 **Kjøleskap**  
Bruksanvisning

FI 145 **Jääkaappi**  
Käyttöohje

---

D

Fordern Sie weitere Informationen zur umfangreichen Produktpalette aus dem Hause WAECO. Bestellen Sie einfach unsere Kataloge kostenlos und unverbindlich unter der Internetadresse: [www.dometic-waeco.de](http://www.dometic-waeco.de)

---

GB

We will be happy to provide you with further information about WAECO products. Please order our free catalogue with no obligation to buy on our homepage: [www.dometic-waeco.com](http://www.dometic-waeco.com)

---

F

Demandez d'autres informations relatives à la large gamme de produits de la maison WAECO. Commandez tout simplement notre catalogue gratuitement et sans engagement à l'adresse internet suivante : [www.dometic-waeco.com](http://www.dometic-waeco.com)

---

E

Solicite más información sobre la amplia gama de productos de la empresa WAECO. Solicite simplemente nuestros catálogos de forma gratuita y sin compromiso en la dirección de Internet: [www.dometic-waeco.com](http://www.dometic-waeco.com)

---

I

Per ottenere maggiori informazioni sull'ampia gamma di prodotti WAECO è possibile ordinare una copia gratuita e non vincolante del nostro Catalogo all'indirizzo Internet: [www.dometic-waeco.com](http://www.dometic-waeco.com)

---

NL

Maak kennis met het omvangrijke productscale van de firma WAECO. Bestel onze catalogus gratis en vrijblijvend onder het internetadres: [www.dometic-waeco.com](http://www.dometic-waeco.com)

---

DK

Bestil yderligere information om det omfattende produktudvalg fra WAECO. Bestil vores katalog gratis og uforpligtende på internetadressen: [www.dometic-waeco.com](http://www.dometic-waeco.com)

---

S

Inhämta mer information om den omfattande produktpaletten från WAECO: Beställ våra kataloger gratis och utan förpliktelser under vår Internetadress: [www.dometic-waeco.com](http://www.dometic-waeco.com)

---

N

Be om mer informasjon om det rikholdige produktutvalget fra WAECO. Bestill vår katalog gratis uforbindtlig på Internettadressen: [www.dometic-waeco.com](http://www.dometic-waeco.com)

---

FIN

Pyytää lisää tietoja WAECO:n kattavista tuotevalikoimista. Tilatkaa tuotekuvastomme maksutta ja sitoumuksetta internet-osoitteesta: [www.dometic-waeco.com](http://www.dometic-waeco.com)

---

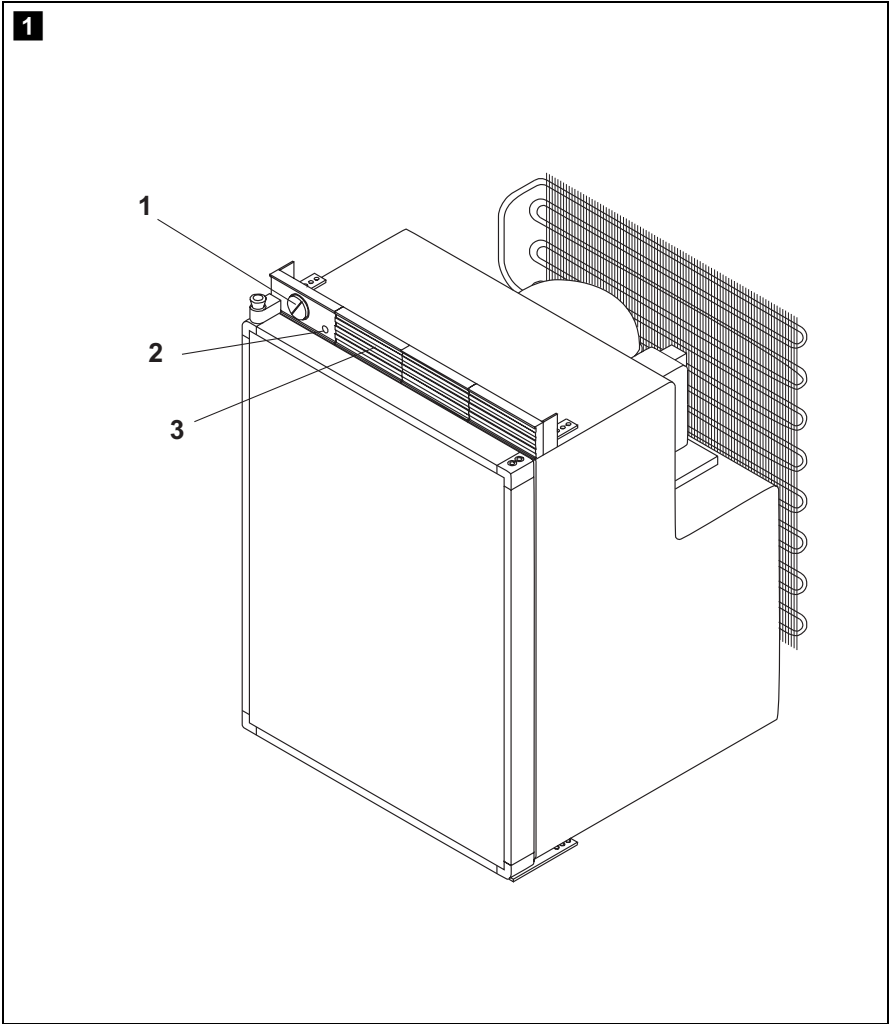

**2**

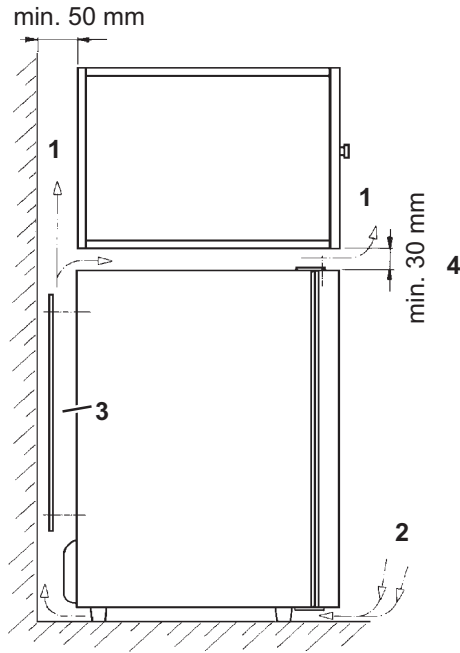

**3**

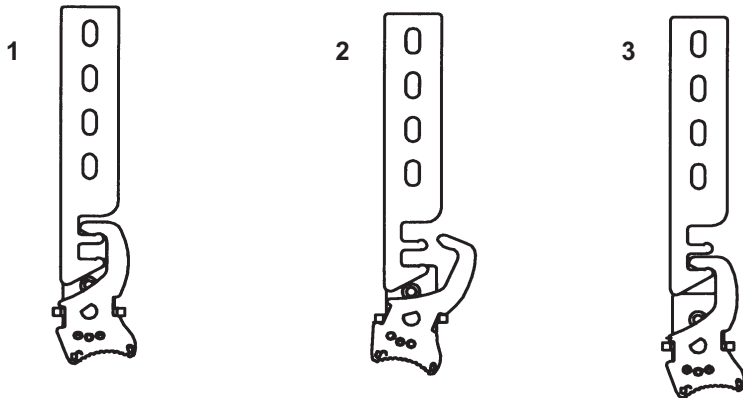

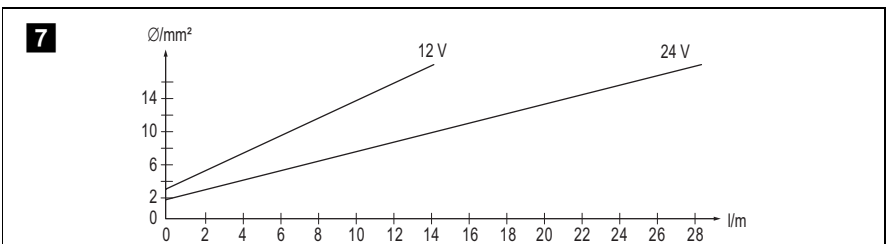
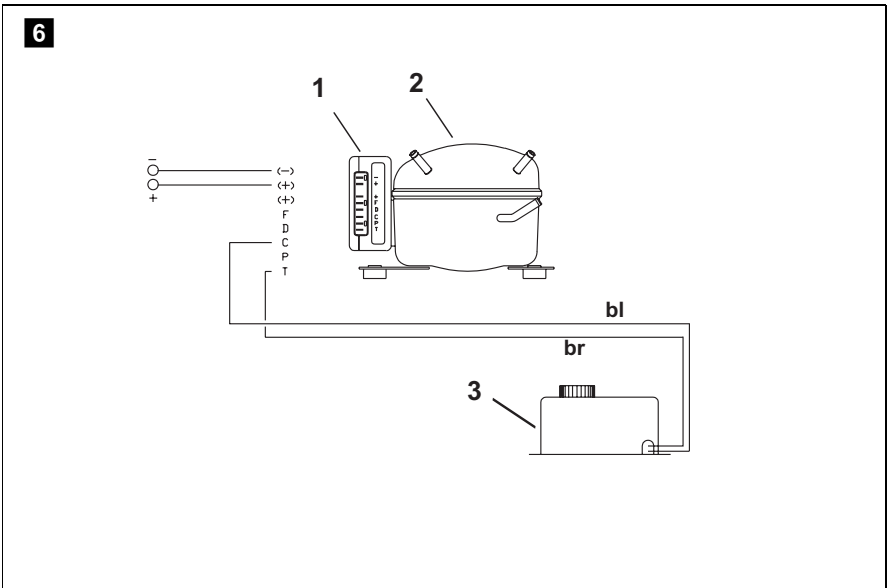
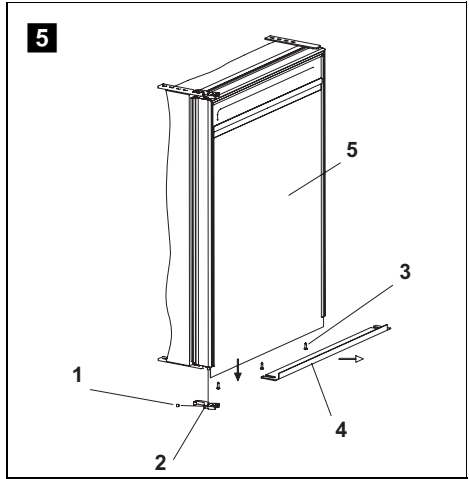
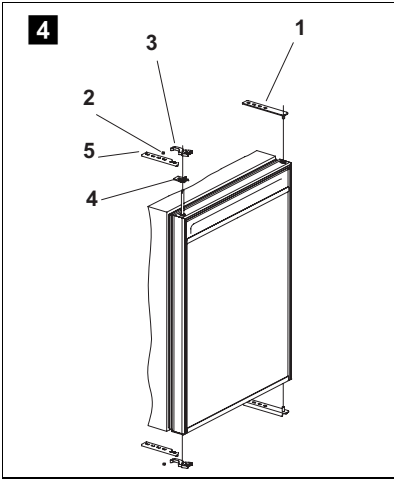

**Please read this operating manual carefully before starting the device. Keep it in a safe place for future reference. If the device is resold, this operating manual must be handed over to the purchaser along with it.**

## Contents

1	Notes on using the operating manual	22
2	Safety instructions	23
3	Intended use	24
4	Scope of delivery	25
5	Technical description	25
6	Setting up and connecting the cooling device	26
7	Operation	30
8	Cleaning and maintenance	33
9	Guarantee	33
10	Disposal	33
11	Troubleshooting	34
12	Technical data	36

## 1 Notes on using the operating manual

The following symbols are used in this operating manual:



### Caution!

**Safety instruction:** failure to observe this instruction can cause injury or damage the device.



### Caution!

**Safety instruction** relating to a danger from an electrical current or voltage. Failure to observe this instruction can damage the device and impair its function and cause injury.



### Note

Supplementary information for operating the device.

- **Action:** this symbol indicates that action is required on your part. The required action is described step-by-step.
- ✓ This symbol indicates the result of an action.

fig. **2** 1, page 3: this refers to an element in an illustration. In this case, item 1 in figure **2** on page 3.

Please observe the following safety instructions.

## 2 Safety instructions



### Caution!

WAECO International will not be held liable for claims for damage resulting from the following:

- Damage to the device resulting from mechanical influences and overvoltage
- Alterations to the device made without the explicit permission of WAECO International
- Use for purposes other than those described in the operating manual

### 2.1 General safety



- Have a trained technician make installations in wet rooms.
- This device may only be repaired by qualified personnel. Inadequate repairs can lead to considerable hazards. Should your device need to be repaired, please contact WAECO customer services.
- Do not open the refrigerant circuit under any circumstances.
- Set up the device in a dry location where it is protected against splashing water.
- Do not place the device near naked flames or other heat sources (heaters, direct sunlight, gas ovens etc.)
- If you connect your refrigerator to a battery, please remember that the battery contains acid.
- Ensure that the ventilation slots are not covered.
- The cooling device is not suitable for transporting caustic materials or materials containing solvents.
- **Electronic devices are not toys!**  
Always keep and use the device out of the reach of children.
- Food may only be stored in its original packaging or in suitable containers.



- Before starting up the device for the first time, check whether the operating voltage and the battery voltage correspond (see type plate).
- **Danger of fatal injuries!**  
**When using the device on boats:** if the device is powered by the mains, ensure that the power supply has a ground fault interrupter circuit.
- If the connection cable is damaged, it must be replaced to prevent possible electrical hazards. Only replace a damaged connection cable with a connection cable of the same type and specifications.

## 2.2 Operating the device safely



- Do not place any electrical devices inside the refrigerator.
- Defrost the device in good time to save energy.
- If you connect the device to a battery, make sure that food does not come into contact with the battery acid.
- Protect the device against rain and moisture.



- Disconnect the cooling device and other power consuming devices from the battery before connecting the battery to a quick charging device.  
Overvoltage can damage the electronics of the device.



- **Note:**  
Disconnect the device if you are not going to use it for a long time.



- **Danger of fatal injuries!**  
Do not touch exposed cables with your bare hands. This especially applies when operating the device with an AC mains power supply.

## 3 Intended use



The refrigerator is suitable for cooling and freezing foodstuffs. The device is also suitable for use on boats.



If you wish to cool medicines, please check if the cooling capacity of the device is suitable for the medicine in question.

## 4 Scope of delivery

Quantity	Description
----------	-------------

1	Refrigerator
1	Assembly kit for changing the door hinge
1	Operating manual

### 4.1 Accessory

If you wish to operate the cooling device with a 230 V AC mains supply, please use one of the following rectifiers:

Description	Item number
MOBITRONIC rectifier	EPS-100W
MOBITRONIC rectifier	MPS-35

## 5 Technical description

COOLMATIC MDC series refrigerators are suitable for use with a 12 V or 24 V DC voltage and can therefore also be used for camping or on boats. You can also use the MOBITRONIC EPS-100W and MPS-35 rectifiers to connect them to a 230 V mains supply.

The refrigerator can chill products and keep them cool. Products can be deep-frozen in the freezer compartment.

You can use the continuously variable thermostat to set the desired temperature.

All materials used in the refrigerator are compatible for use with foodstuffs. The refrigerant circuit is maintenance-free.

When used on boats the refrigerator can be subjected to a constant inclination of 30°.

## 5.1 Operating and display elements

No. in  
fig. **1**,  
page 3

No.	Explanation
1	Temperature controller
2	Error code LED
3	Operating panel with ventilation slots (only MDC-90 and MDC-110)

Error codes in the error code LED, see chapter “Troubleshooting” on page 34.



On the MDC-90 and MDC-110 models the temperature control and the error code LED are on the device operating panel. On the MDC-50 and MDC-65 models, the temperature control and the LED are integrated in the device.

## 6 Setting up and connecting the cooling device

### 6.1 Setting up the cooling device

The device is designed for ambient temperatures between +16 °C and +32 °C. In continuous operation, the air humidity may not exceed 90 %.

Set up the cooling device in a dry, sheltered place. Avoid placing it near heat sources such as radiators, gas ovens or hot water pipes. Do not let it stand in the direct, strong sunlight.

The cooling device must be positioned so that heated air can dissipate easily. Therefore make sure there is adequate ventilation (fig. **2**, page 4).

No. in  
fig. **2**,  
page 4

No.	Explanation
1	Hot waste air
2	Cold intake air
3	Condenser
4	With cover panel 50 mm above

## 6.2 Sealing system

The cooling device has a locking mechanism to protect it during transport. The following settings are possible:

- Position 1 (transport lock): (fig. **3** 1, page 4) The door is locked and secured. To open the door, turn the bolt to position 2.
- Position 2 (releasing transport lock): (fig. **3** 2, page 4) The door can be opened.
- Position 3 (VENT position): (fig. **3** 3, page 4) The door is slightly open, but fixed in position. Use this position, for example, if you are not going to use the device for a long time.

## 6.3 Changing the door hinge

You can also change the hinge of the door, so that it opens to the left rather than the right.

To change the door hinge, proceed as follows (fig. **4**, page 5):

- Remove the upper door hinge (fig. **4** 1, page 5).
- Carefully lift out the door.
- Remove the threaded pins (fig. **4** 2, page 5).
- Pull the locking hook (fig. **4** 3, page 5) off the rod.
- Remove the locking plate (fig. **4** 4, page 5) and fit it on the opposite side.
- Pull the rod downwards and out and put it in the other side.
- Fasten the locking hook (fig. **4** 3, page 5) back on the rod.
- Detach the top and bottom lock holders (fig. **4** 5, page 5) on the left side.
- Detach the top and bottom door hinges (fig. **4** 1, page 5) on the right side.
- Fasten the top and bottom door hinges (fig. **4** 1, page 5) to the left side.
- Fasten the top and bottom lock holders (fig. **4** 5, page 5) to the left side.

## 6.4 Changing the decorative plate

You can change the decorative plate on your cooling device to improve the appearance.

This is how to change the decorative plate:

- Remove the screws 1 and 3 (fig. **5** 1 and 3, page 5).
- Remove components 2 and 4 (fig. **5** 2 and 4, page 5).
- Pull down the old decorative plate out of the door frame.  
Caution: there is a risk of injury!
- Put the new decorative plate in the door frame.
- Fit the components 2 and 4 (fig. **5** 2 and 4, page 5) back on the device.
- Fasten the screws 1 and 3 (fig. **5** 1 and 3, page 5).

## 6.5 Connecting the cooling device

For the electrical connection you also need the wiring diagram (fig. **6**, page 5).

No. in fig. <b>6</b> , page 5	Meaning
1	Electronic terminal rail
2	Compressor
3	Temperature controller

Cable colours:

No. in fig. <b>6</b> , page 5	Meaning
bl	Blue
br	Brown

### Connecting to a battery

The cooling device can be operated with a 12 V or 24 V DC voltage supply.



To avoid voltage loss and therefore a drop in performance, the cable should be kept as short as possible and should not be interrupted if this is possible.

For this reason avoid additional switches, plugs or power strips.

- Determine the required cross section of the cable in relation to the cable length according to fig. **7**, page 5.

Key for fig. **7**, page 5

Co-ordinate axis	Meaning	Unit
l	Cable length	m
∅	Cable cross section	mm <sup>2</sup>



#### Caution!

Make sure that the polarity is correct.

- Before starting up the device for the first time, check whether the operating voltage and the battery voltage correspond (see type plate).
- Connect the cooling device
  - As directly as possible to the pole of the battery or
  - To a plug socket which is fused with at least 15 A (at 12 V) or 7.5 A (at 24 V).



#### Caution!

Disconnect the cooling device and other power consuming devices from the battery before connecting the battery to a quick charging device.

Overvoltage can damage the electronics of the device.

The cooling device is equipped with an electronic device to protect against reversing the polarity and short circuits when connecting to a battery.

To protect the battery, the cooling device switches off automatically if the voltage is insufficient (see table below).

	<b>12 V</b>	<b>24 V</b>
<b>Switch-off voltage</b>	10.4 V	22.8 V
<b>Switch-on voltage</b>	11.7 V	24.2 V

## Connecting to 230 V mains supply



### **Danger of fatal injuries!**

Never handle plugs and switches with wet hands or if you are standing in a puddle.



If you are operating your cooling device on board a boat with a mains connection of 230 V from the land, you must install a ground protection circuit breaker between the 230 V mains supply and the cooling device.

Seek advice from a trained technician.

- To operate the cooling device with a 230 V mains supply, use an EPS-100 W or MPS-35 MOBITRONIC rectifier.

## 7 Operation



Before starting your new cooling device for the first time, you should clean it inside and outside with a damp cloth for hygienic reasons (please also refer to the chapter “Cleaning and maintenance” on page 33).

### 7.1 Energy saving tips

- Choose a well ventilated installation location which is protected against direct sunlight.
- Allow food to cool down first before placing it in the device.
- Do not open the cooling device more often than necessary.
- Do not leave the door open for longer than necessary.
- Defrost the cooling device as soon as a layer of ice forms.
- Avoid unnecessarily low temperatures.
- Clean the condenser of dust impurities at regular intervals.

### 7.2 Using the cooling device

The cooling device conserves fresh foodstuffs. The freezer compartment conserves frozen foodstuffs and freezes fresh foodstuffs.



### **Caution!**

Ensure that food or liquids in glass containers are not excessively refrigerated.

Liquids expand when they freeze and can thus destroy the glass containers.

- Switch the cooling device on by turning the knob (fig. **1** A, page 3) to the right.



After switching on, the cooling device requires approx. 60 s until the compressor starts up.



### Caution!

Ensure that the objects placed in the cooling device are suitable for cooling to the selected temperature.

## Setting the temperature

You can set the temperature to any level using the knob. The built-in temperature control regulates the temperature as follows:

- min. (left limit) = warmest setting
- max. (right limit) = coldest setting



The cooling capacity can be influenced by:

- The ambient temperature
- The amount of food to be conserved
- The frequency with which the door is opened

## Conserving foodstuffs

You can conserve foodstuffs in the cooling device compartment. The time for which the food can be conserved in this way is usually stated on the package.



### Caution!

Do not conserve **warm** food in the cooling device compartment. Do not place glass containers with liquid in the freezer compartment.



Food which can easily absorb tastes and odours and liquids and products with a high alcohol content should be conserved in air-tight containers.

The cooling device compartment is divided in different zones with different temperatures:

- The colder zones are immediately over the base, near the back wall.
  - Observe the temperature information and best before date on the food packaging.
- Observe the following when using the device:
- Do not re-freeze products which are defrosting or have been defrosted, consume them as soon as possible.

- Wrap food in aluminium foil or cling film and shut it in a suitable box with a lid. This ensures that aromas, the shape and the freshness are better conserved.

### Securing the refrigerator door

You can prevent the refrigerator door from being opened inadvertently.

- ▶ Put the locking mechanism on the top of the door to position 1 (fig. **3** 1, page 4).

### Defrosting the cooling device

Humidity can form frost in the interior of the cooling device or on the vaporiser. This reduces the cooling capacity. Defrost the device in good time to avoid this.



#### Caution!

Never use hard or pointed tools to remove ice or to loosen objects which have frozen in place.

To defrost the cooling device, proceed as follows:

- ▶ Take out the contents of the cooling device.
- ▶ Place them in another cooling device to keep them cool, if necessary.
- ▶ Set the knob to 0.
- ▶ Leave the door open.
- ▶ Wipe off the water resulting from defrosting or – if present – empty the collecting tray. If your device has a water drain, drain the thawed water off.

### Switching off and storing the cooling device

If you do not intend to use the cooling device for a long time, proceed as follows:

- ▶ Turn the knob to 0.
- ▶ Disconnect the power cable from the battery or pull the DC cable plug out of the rectifier.
- ▶ Clean the cooling device (see chapter “Cleaning and maintenance” on page 33).
- ▶ Leave the lid or door open for to avoid unpleasant odours building up.
- ▶ Put the lock in the VENT position.  
This prevents odours from building up.

## 8 Cleaning and maintenance

**Caution!**

Do not use abrasive cleaning agents or hard objects during cleaning as these can damage the cooling device.

**Caution!**

Never use brushes, scouring pads or hard or pointed tools to remove ice or to loosen objects which have frozen in place.

- Clean the cooling device regularly as soon as it becomes dirty with a damp cloth.
- Make sure that no water drips into the sealings. This can damage the electronics.
- Wipe the cooling device dry with a cloth after cleaning.

## 9 Guarantee

The statutory warranty period applies. If the product is defective, please contact the manufacturer's branch in your country (see the back of the instruction manual for the addresses) or your retailer.

For repair and guarantee processing, please include the following documents when you send in the device:

- A copy of the receipt with purchasing date
- A reason for the claim or description of the fault

## 10 Disposal

**Caution!**

When disposing of the device, make sure it is not overheated, as the insulating foam was made with flammable gas.

- Place the packaging material in the appropriate recycling waste bins wherever possible.



If you wish to finally dispose of the product, ask your local recycling centre or specialist dealer for details about how to do this in accordance with the applicable disposal regulations.

# 11 Troubleshooting

## Error code LED

The error code LED indicates various faults with a different number of flashes. One flash lasts a 1/4 of a second. The error codes are repeated every 4 seconds.

Number of flashes	Error type	Possible cause
1	Battery protection shut down	The battery voltage is outside of the set range
2	Fan overvoltage shut down	The fan is consuming more than 0.5 A on average or 1 A peak values from the electronic unit
3	Motor start error	The rotor is stuck or the differential pressure in the cooling system is too high (> 5 bar)
4	RPM too low	If the cooling system is overloaded, the minimum speed of the motor of 1900 RPM cannot be maintained
5	Thermal shut down of the electronic unit	If the cooling system is overloaded or the ambient temperature is too high, the electronic unit becomes too hot

## Compressor does not run

Fault	Possible cause	Remedy
$U_T = 0\text{ V}$	The connection between the battery and the electronics is interrupted	Establish a connection
	Main switch defective (if installed)	Replace the main switch
	Additional supply line fuse has blown (if installed)	Replace the fuse
$U_T \leq U_{ON}$	Battery voltage is too low	Charge the battery
Start attempt with $U_T \leq U_{OFF}$	Loose cables	Establish a connection
	Poor contact (corrosion)	
	Battery capacity too low	Replace the battery
	Cable cross section too low	Replace the cable (fig. 7, page 5)
Start attempt with $U_T \leq U_{ON}$	Ambient temperature too high	–
	Insufficient ventilation	Move the cooling device
	Condenser is dirty	Clean the condenser
	Fan defective (if installed)	Replace the fan

$U_T$  Voltage between the positive and negative electronic terminals

$U_{ON}$  Switch-on voltage of the electronics

$U_{OFF}$  Switch-off voltage of the electronics

### Interior temperature too low in control setting 1

Fault	Possible cause	Remedy
Compressor runs constantly	Thermostat sensor has no contact to the vaporiser	Secure the sensor
	Thermostat defective	Change the thermostat
	Short circuit in the thermostat line	
Compressor runs for a long time	A large quantity has been frozen in the freezer compartment	–

### Cooling capacity drops, interior temperature rises

Fault	Possible cause	Remedy
Compressor runs for a long time/continuously	Vaporiser iced over	Defrost the vaporiser
	Ambient temperature too high	–
	Insufficient ventilation	Move the cooling device
	Condenser is dirty	Clean the condenser
	Fan defective (if installed)	Replace the fan
Compressor does not run often	Battery capacity exhausted	Charge the battery

### Unusual noises

Fault	Possible cause	Remedy
Loud humming	A component of the refrigerant circuit cannot move freely (lies against the wall)	Bend the component carefully
	Foreign body jammed between the cooling device and the wall	Remove the foreign body
	Fan noise (if installed)	–

## 12 Technical data

All MDC series refrigerators have the following features:

- Connection voltage 12 V DC or 24 V DC
- Cooling device compartment temperature: +10 °C to +2 °C
- Freezer compartment temperature: 0 °C to -18 °C
- Relative humidity: maximum 90 %
- Constant inclination: maximum 30°



- Test/certificates:  
complies with ErP/EuP directive

	<b>MDC-50</b>	<b>MDC-65</b>
Overall capacity:	43 l	64 l
Freezer compartment:	4 l	10 l
Average power consumption:	45 W	
Dimensions (WxHxD) in mm:	425x620x445	485x673x475
Weight:	15 kg	20 kg
	<b>MDC-90</b>	<b>MDC-110</b>
Capacity:	90 l	110 l
Freezer proportion:	10 l	13 l
Average power consumption:	45 W	
Dimensions (WxHxD) in mm:	485x830x475	525x805.5x547
Weight:	28 kg	30.5 kg

Versions, technical modifications and delivery options reserved.

The coolant circuit contains R134a.