

LE-300

Technical Spec Sheet



About the LE-300

Incredibly quiet, light and with fantastic power production the LE-300 wind generator is ideal for boats, yachts and barges.

The LE-300 features a fully integrated 3-phase Permanent Magnet Generator (PMG) that uses the latest, most powerful neodymium iron boron magnet technology. This gives the LE-300 a very low cut-in speed allowing the turbine to generate power at low windspeeds, as well as delivering a higher output than the competition at higher windspeeds.

Designed and manufactured in the UK, the turbine blades are incredibly quiet, UV resistant and extremely tough. Of equal importance, is the LE300's ability to run at high output during high winds for prolonged periods as it is designed to run through even the highest winds.

The charge controller prevents the turbine overcharging the battery by using a dump load. Simply put, this means that when the batteries are full, any excess energy is simply diverted to a dumpload (effectively a small heating element). The advantage of this system is that the turbine can continue to spin under load. This means it continues to operate quietly, as opposed to being turned on and off as with other charge controllers, which is noisy and is not good for turbine longevity.

The LE-300 wind generator will generate more ampHours compared to competitor products.

Features and Benefits of the LE-300 wind generator for boats

- High power output in all wind conditions; more powerful than the market leader above 10knots (Force 4 or more)
- Low RPM rotor blades mean exceptionally quiet operation.
- Designed to run through severe weather conditions
- All-up weight of just 8.8kg
- Unique bearing configuration resulting in low friction, low bearing noise.
- All bearings are lubricated and sealed for life
- Anti-vibration fixings and mounts used throughout.
- Designed and manufactured in the UK
- Fully marineised construction from powder coated / anodized aluminium and stainless steel.
- Unique axial flux generator design, using powerful neodymium magnets, allows effortless start up in low winds and reduces 'generator hum'.
- Tail fin especially designed for excellent response to turbulent wind conditions

LE-300

Technical Spec Sheet



LE-300

Average Daily Energy Production (est.)

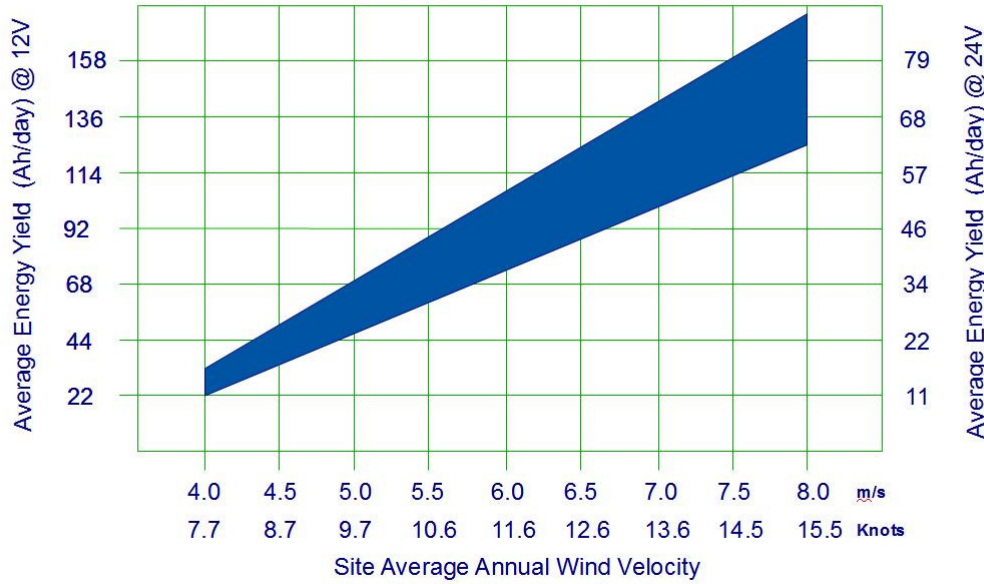

LE-300

Power Curve

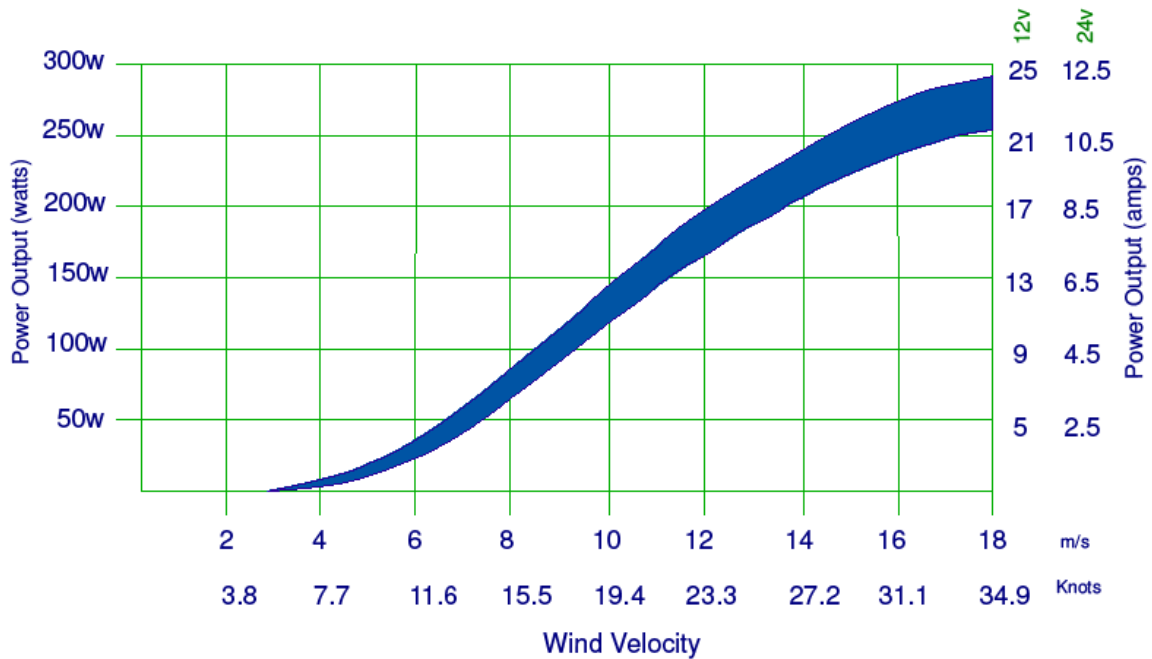

Contact us at: www.leturbines.com sales@leturbines.com 0845 652 0396

LE-300

Technical Spec Sheet

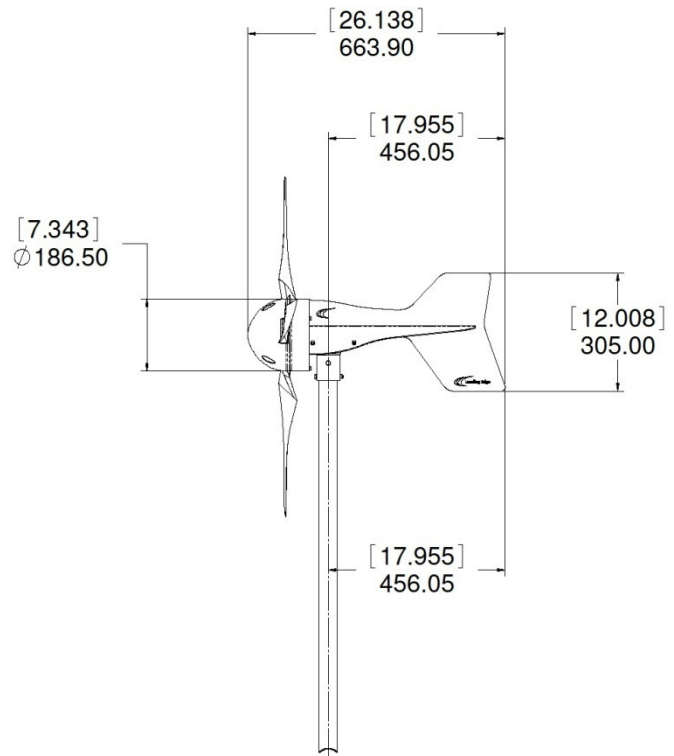
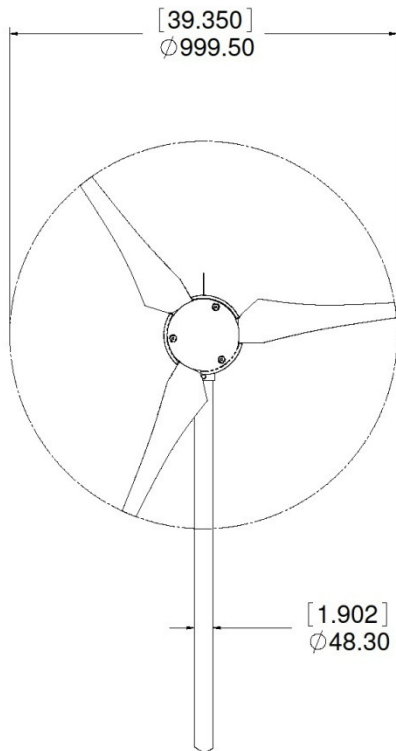

Specifications

Rotor Diameter:	1 metre	Weight:	8.8 Kg
Rotor Type:	3-Blade upwind	Generator Type:	3-Phase Brushless NIB rotor PMA
Blade Material:	Glass Reinforced Nylon	Output voltage:	12 or 24V
Rated Output:	85watts @ 8m/s (18mph)	Lifetime & Servicing:	20 years Annual inspection recommended
Peak Output:	300watts	Warranty	2 years
Cut-in speed:	3m/s (6.7mph)		
Estimated AEP:	250-400kWh per year Depending on site location & wind		