

# PS200 HR

## Solar-operated Submersible Pump System, 4" Helical Rotor (HR) Pump Unit

### Characteristics

- lift up to 50 m
- flow rate up to 2.7 m<sup>3</sup>/h
- simple installation
- maintenance-free
- high reliability and life expectancy
- cost-efficient pumping

### Applications

- drinking water supply
- livestock watering
- pond management
- irrigation
- etc.

### Components

#### Controller PS200

- controlling of the pump system and monitoring of the operating states
- mounted at surface (no electronic parts submerged)
- two control inputs for well probe (dry running protection), float or pressure switches, remote control etc.
- automatic reset 20 minutes after well probe turns pump off
- protected against reverse polarity, overload and high temperature
- speed control, max. pump speed adjustable to reduce flow rate to c. 30 %
- solar operation: integrated MPPT (Maximum Power Point Tracking)
- battery operation: low voltage disconnect and restart after battery has recovered
- max. efficiency 92 % (motor + controller)
- enclosure: IP 54 (sealed, weatherproof)

#### Motor ECDRIVE 600HR

- brushless DC motor
- no electronics inside motor
- water filled
- IP68, pressure balanced, unlimited submersion
- dynamic slide bearings, material: carbon/ceramic
- wetted material: stainless steel (AISI 316), POM, rubber, cable drinking water approved

#### Pump End (PE)

- helical rotor pump (positive displacement pump)
- two main parts only: stator and rotor, field serviceable
- stator: geometry made of abrasion resistant rubber
- rotor: stainless steel, hard chrome plated, abrasion resistant
- more resistant to damage by sand than other pump types
- high life expectancy
- non-return valve
- dry running protection (optional)
- material: stainless steel (AISI 316), rubber
- self-cleaning

### Performance

PS200	HR-04	HR-07	HR-14
article #	1007-X	1009-X	1008-X
lift [m]	0–50	0–30	0–20
max. flow rate [m <sup>3</sup> /h]	0.8	1.2	2.7
max. efficiency [%]	60	61	62
solar operation	nominal voltage 24–48VDC, open circuit voltage max. 100VDC		
solar generator [Wp]	80–300	80–300	80–300
battery operation	nominal voltage 24–48VDC		



### System Sizing Table: Battery Operation

PS200 HR, 24V, Battery Operation

vertical lift		pump type	peak flow rate		power [W]	wire size [mm <sup>2</sup> ]
[m]	[ft]		[l/min]	[US Gal/min]		
5	16	HR-04	5.5	1.5	24	2.5
		HR-07	7.5	2.0	37	
		HR-14	17.5	4.6	40	
10	33	HR-04	5.2	1.4	29	2.5
		HR-07	7.5	2.0	42	
		HR-14	16.6	4.4	55	
15	50	HR-04	4.8	1.3	34	2.5
		HR-07	7.0	1.8	50	
		HR-14	15.2	4.0	74	
20	65	HR-04	4.5	1.2	38	2.5
		HR-07	6.5	1.7	60	
		HR-14	12.5	3.3	91	
30	100	HR-04	4.2	1.1	48	4.0
40	130	HR-04	3.8	1.0	58	4.0
50	165	HR-04	3.3	0.9	65	4.0

PS200 HR, 48V, Battery Operation

vertical lift		pump type	peak flow rate		power [W]	wire size [mm <sup>2</sup> ]
[m]	[ft]		[l/min]	[US Gal/min]		
5	16	HR-04	11.0	2.9	55	2.5
		HR-07	17.0	4.5	90	
		HR-14	38.4	10.1	130	
10	33	HR-04	10.3	2.7	70	2.5
		HR-07	16.5	4.4	100	
		HR-14	36.1	9.5	165	
15	50	HR-04	10.1	2.7	80	2.5
		HR-07	15.8	4.2	115	
		HR-14	35.0	9.2	195	
20	65	HR-04	9.8	2.6	90	2.5
		HR-07	15.5	4.1	135	
		HR-14	35.0	9.2	195	
30	100	HR-04	9.3	2.5	105	4.0
		HR-07	14.2	3.8	160	
40	130	HR-04	8.7	2.3	125	4.0
		HR-07	13.5	3.6	190	
50	165	HR-04	7.8	2.1	140	4.0

#### For Battery and Solar Direct Systems

##### Lift Limits

These systems are selected for optimum performance. To allow unexpected drawdown, each system can handle an additional 15% lift.

##### Higher Lift? Higher Flow Rate?

Choose PS600/1200 for higher lift, higher flow rate applications and lower cable cost.

##### Wire Sizes

Cable Layout is calculated to stay within 4% power loss.

##### Variations of Length

Longer: for each 50% increase, the next larger wire size is required

Shorter: for each 33% decrease, the next smaller wire size is required

Array To Controller: if shorter than 6m/20ft: 4mm<sup>2</sup> / #10 min.

Controller To Low-Water Probe: 1mm<sup>2</sup>/#18 min. 2-conductor

#### For Solar Direct Systems

##### System Voltage

24-48V nominal, e.g. 2 to 4 standard 12V modules wired in series, Voc 100V max.

##### How Daily Water Volume Is Calculated

Daily volume is calculated by integrating real flow versus realistic solar (PV) output through the day.

The solar array is fixed at tilt angle = latitude of the location.

irradiation:

kWh/m<sup>2</sup>/day = peak sun hours/day

Flow rates may vary +/- 10%

### System Sizing Table: Solar-direct operation

#### PS200 HR, 24V nominal voltage 2× 12V standard modules in series

irradiation 4.0 kWh/m<sup>2</sup>/day, tilted surface

vertical lift		pump type	peak flow rate	flow rate for PV array power peak			wire size
[m]	[ft]			[l/min]	80Wp	120Wp	
5	16	HR-04	7.2	2.2	2.5	2.8	2.5
		HR-07	13.0	2.0	3.5	4.7	
10	33	HR-04	6.5	2.0	2.3	2.6	2.5
		HR-07	13.0	1.7	3.0	4.2	
15	50	HR-04	6.0	1.8	2.0	2.4	2.5
		HR-07	12.0	1.5	2.8	3.9	
20	65	HR-04	5.8	1.4	1.6	2.2	2.5
		HR-07	12.0	1.1	2.5	3.7	
25	82	HR-04	5.7	1.1	1.5	2.1	2.5
30	100	HR-04	5.5	0.8	1.2	2.0	2.5
40	130	HR-04	5.1	-	1.0	1.8	4.0
50	165	HR-04	5.1	see 36-48V table			4.0

irradiation 6.0 kWh/m<sup>2</sup>/day, tilted surface

vertical lift		pump type	peak flow rate	flow rate for PV array power peak			wire size
[m]	[ft]			[l/min]	80Wp	120Wp	
5	16	HR-04	7.2	3.5	3.8	4.0	2.5
		HR-07	13.0	4.0	6.0	7.0	
10	33	HR-04	6.5	3.3	3.6	4.0	2.5
		HR-07	13.0	3.9	5.2	5.4	
15	50	HR-04	6.0	2.9	3.5	4.0	2.5
		HR-07	12.0	3.5	5.0	5.2	
20	65	HR-04	5.8	2.5	3.3	3.9	2.5
		HR-07	12.0	2.4	3.8	4.9	
25	82	HR-04	5.7	2.2	3.0	3.5	2.5
30	100	HR-04	5.5	1.9	2.8	3.1	2.5
40	130	HR-04	5.1	-	2.0	2.5	4.0
50	165	HR-04	5.1	see 36-48V table			4.0

#### PS200 HR, 36-48V nominal voltage 3–4× 12V standard modules in series

irradiation 4.0 kWh/m<sup>2</sup>/day, tilted surface

vertical lift		pump type	peak flow rate	flow rate for PV array power peak			wire size
[m]	[ft]			[l/min]	150Wp	200Wp	
5	16	HR-04	12.0	4.8	5.4	6.4	2.5
		HR-07	19.5	4.7	7.0	8.5	
10	33	HR-04	11.8	4.5	5.0	6.0	2.5
		HR-07	19.0	4.2	6.0	7.5	
15	50	HR-04	11.5	4.0	4.6	5.7	2.5
		HR-07	18.5	3.9	6.0	7.4	
20	65	HR-04	11.5	3.5	4.2	5.4	2.5
		HR-07	18.0	3.3	5.5	7.0	
25	82	HR-04	11.3	2.6	3.6	5.1	2.5
		HR-07	17.5	-	2.5	4.0	
30	100	HR-04	11.0	2.0	3.0	4.8	2.5
40	130	HR-04	11.0	1.7	2.4	3.5	4.0
50	165	HR-04	10.5	1.3	2.0	3.0	4.0

irradiation 6.0 kWh/m<sup>2</sup>/day, tilted surface

vertical lift		pump type	peak flow rate	flow rate for PV array power peak			wire size
[m]	[ft]			[l/min]	150Wp	200Wp	
5	16	HR-04	12.0	6.3	6.6	7.3	2.5
		HR-07	19.5	8.5	9.5	10.5	
		HR-14	36.0	11.0	15.0	18.0	
10	33	HR-04	11.8	6.0	6.5	7.0	2.5
		HR-07	19.0	8.0	9.0	10.0	
		HR-14	34.0	9.0	13.0	16.0	
15	50	HR-04	11.5	5.5	6.0	6.8	2.5
		HR-07	18.5	7.0	8.3	9.5	
		HR-14	33.0	8.0	11.0	14.0	
20	65	HR-04	11.5	5.5	6.2	6.6	2.5
		HR-07	18.0	6.0	7.5	9.0	
		HR-04	11.3	5.0	5.6	6.2	
25	82	HR-07	17.5	5.0	6.5	8.0	2.5
		HR-04	11.0	4.3	4.9	5.8	
30	100	HR-04	11.0	3.0	4.0	5.0	4.0
40	130	HR-04	11.0	3.0	4.0	5.0	4.0
50	165	HR-04	10.5	2.0	3.0	4.2	4.0

#### Conversion for Wire Sizes

AWG	mm <sup>2</sup>
# 18	1
# 12	4
# 10	6
# 8	10
# 6	16

#### Conversion for Flow Rates

1 m <sup>3</sup>	264 US Gal.
1 m <sup>3</sup>	220 Imp. Gal.
1 l/min	0.264 US Gal/min
1 l/min	0.220 Imp. Gal/min

#### Conversion for Lift/Length

1 m	3.3 ft
-----	--------

Table shows nearest larger metric cross section.

## Dimensions and Weights

	dimensions					shipping dimensions			
	L	A	B	D	S	packaging	shipping volume	net weight	gross weight
	[mm]	[mm]	[mm]	[mm]	[mm]	[mm]	[m <sup>3</sup> ]	[kg]	[kg]
<b>Pump Unit (PU) (motor + pump end)</b>									
HR-04	780	595	185	96	G 1 ¼ in	850×160×150	0.0204	11.2	12.0
HR-07, HR-14	771	586	185	96	G 1 ¼ in	850×160×150	0.0204	11.5	12.3
<b>Controller</b>									
PS200						320×240×160	0.0123	1.2	1.8

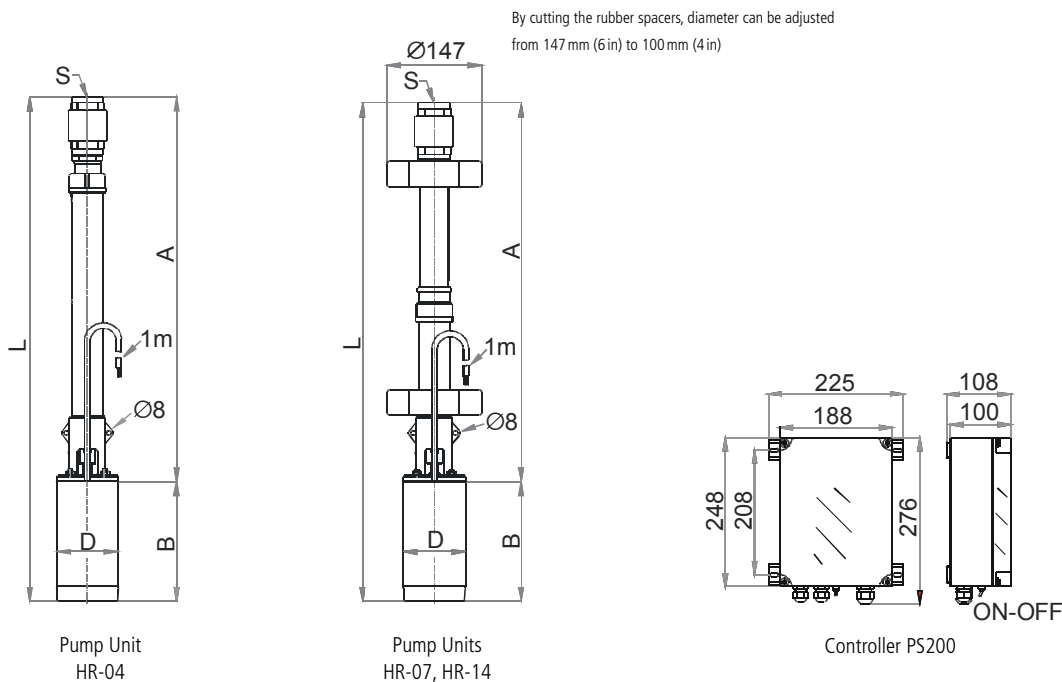

### Sand and Silt Tolerance

The pump (HR) has a higher resistance to wear from sand, clay etc. than any other pump type. In properly constructed wells the amount of solid particles is within the tolerance of the pump.

A concentration of particles higher than 2 % (by volume) may cause blockage in the pump or the drop pipe, especially at low flow rates.

Do not use the pump to clean out a dirty well.

### Pump Cable and Splice

Standard submersible cable, 3-wire + ground (total four wires). Connection to the pump is made using industry-standard splicing methods.

### Drop Pipe

G 1 ¼ in (optional: 1 in NPT) pump outlet. If water is dirty consider a smaller sized drop pipe to increase the flow velocity. This helps to exhaust solid particles and prevent accumulation in the pipe. When considering reduced pipe size, consult a pipe sizing (friction loss) chart. Pipe can be of any standard material, rigid or flexible. A torque arrestor is not required.

### Temperature Limits

Pump end, motor: water temperature up to +40°C (+104°F)

Specify temperature range on order.

Controller: ambient temperature -30°C to +55°C (-22°F to +131°F)

### Warranty

Two years manufacturer's warranty against defects in material and workmanship

Available from:  
[www.solar-wind.co.uk](http://www.solar-wind.co.uk)